





freud

Precisely
the best

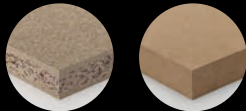

LSBX NeXt Generation
Premium saw blades for panel sizing

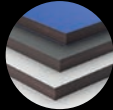
THE MOST COMPLETE RANGE OF CIRCULAR
SAW BLADES FOR PANEL SIZING MACHINES

| | | |
|---------------------------|---|-----|
| CHIPBOARD & MDF |  | ●●● |
| LAMINATED CHIPBOARD & MDF |  | ●●● |
| HPL |  | ●● |
| PLEXIGLAS |  | ●● |

Key of performance
●●● Ultimate ●● High ● Good

FOR AUTOMATIC PANEL SIZING MACHINES

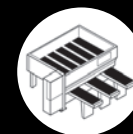

AVAILABLE IN A WIDE RANGE OF DIAMETERS

from 250 mm

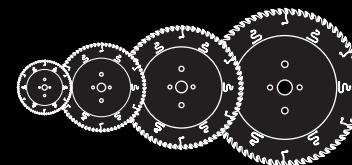

to 720 mm

LSB X PRODUCT FEATURES

WHY FREUD LSB X IS PRECISELY THE BEST FOR PANEL SIZING



EXtraordinary performance
Long lasting TiCo Carbide in-house manufactured.



EXcellent rust protection and anti-friction technology
Silver I.C.E. Coating.



Low noise
Exclusive anti-vibration slots.



EXtended lifetime up to 25 resharpenings
Supersquare tooth design.



EXtreme shock resistance
Special Tri-metal brazing alloy withstands extreme impact.

EXceptional cutting finishing
Increased body stability.

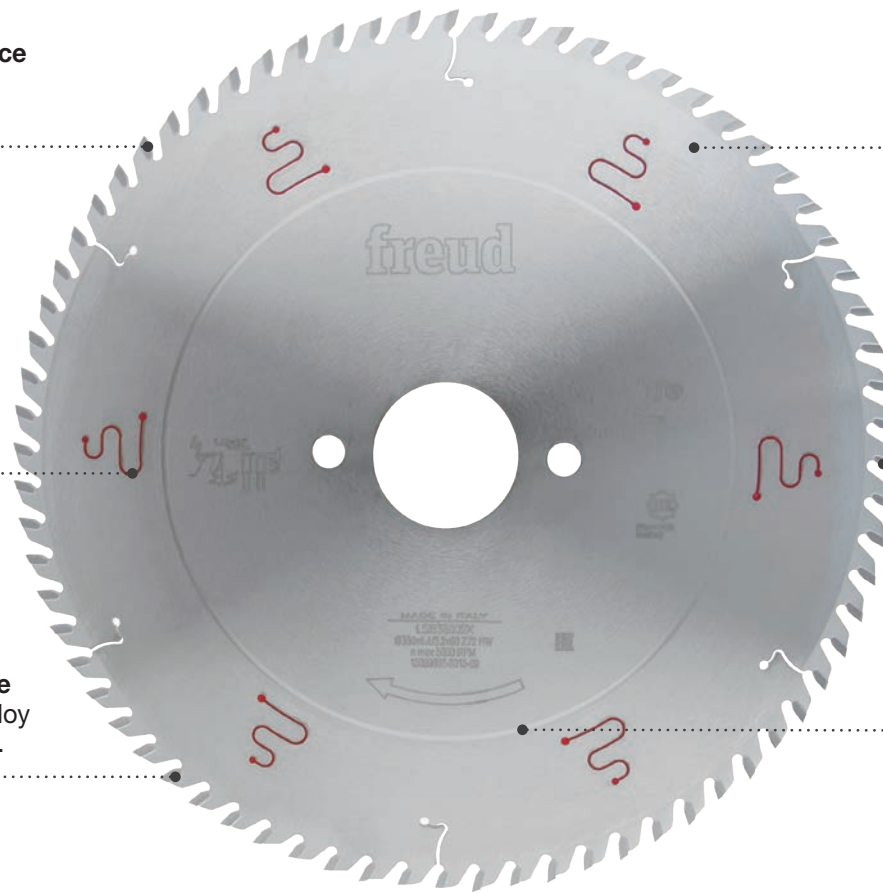

TiCo Carbide

- A specially formulated, highly compact Titanium Cobalt Carbide, engineered and manufactured by freud.
- It provides a sharper edge and flawless finish with a dramatically longer cutting life.



Silver I.C.E. Coating

- A high performing and anticorrosive coating to maintain the blade temperature low during the working process.
- The non-stick feature improves chip ejection and notably reduces resin build-up, significantly reducing friction and extending the lifetime of the blade.



Anti-vibration slots

- Body slots laser cut with freud innovative technology.
- Also available with thermoplastic polyurethane filling, that considerably reduces vibration and minimizes noise.



Suitable for more than

130 panel sizing machines of most popular brands

AES ANTHON AYZA MIZRAK

BIESSE FIMAL FELDER MAYER

GABBIANI GIBEN HOLZER

HOLZMA HOMAG NANXING

NIMAK PANHANS SCHEER KOCH

SCHELLING SCM SCM-GABBIANI

TÖRK MAKINE TURANLAR

EXPLANATION OF SYMBOLS AND ABBREVIATIONS

Guide to product tables

| | | | | | | | |
|----------|----------------------------|----------|------------------------|----------------------------|-----------------------------------|---------------------------|-----------------------|
| D | Outer diameter (mm) | B | Cutting thickness (mm) | B-B1 | Adjustable cutting thickness (mm) | b | Body thickness (mm) |
| d | Central bore diameter (mm) | Z | Number of teeth | α | Hook angle (°) | β | Back relief angle (°) |



Anti-vibration slots

Optimised tooth geometry

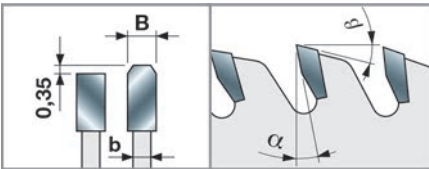

The LSB X range represents the ideal choice for industrial panel sizing. Saw blades suitable for chipboard and MDF bilaminated panels. Good finishing also in HPL and acrylic panels cutting.

Guide to Pin Holes

Example

| Pin Holes | Freud Code | Art. No. |
|-----------------------|------------|----------|
| ● 2/10/60 + ● 2/13/94 | example | example |

Centre to centre distance
Pin holes diameter
Number of pin holes

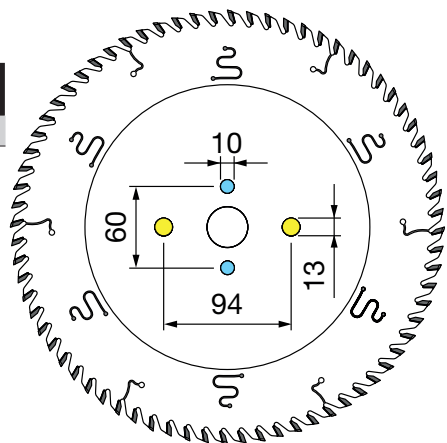

FIND THE PERFECT PANEL SIZING BLADE SET BY MACHINE

BIESSE-SELCO

IES - ANTHON
AYZA MIZRAK

FELDER
MAYER
FIMAL
GIBEN

HOLZER
HOLZMA

HOMAG
NANXING

NIMAC
PANHANS
SCHEER
SCHELLING

SCM-GABBIANI
TÖRK MAKINE
TURANLAR

LSB X RANGE
BY DIAMETER

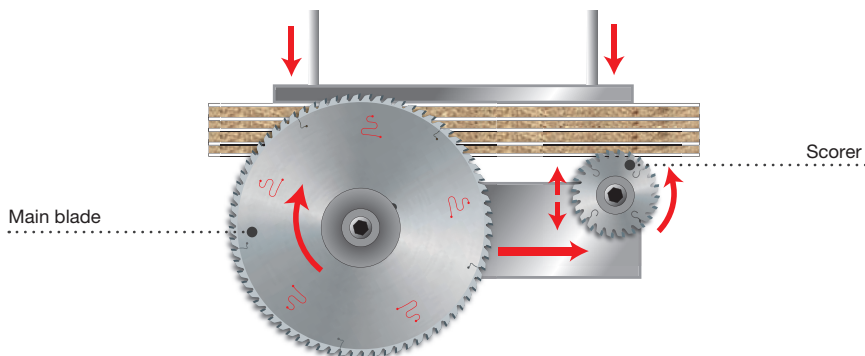

| Machine Type | Tool Type | D mm | B-B1 mm | b mm | d mm | Z | Tooth Type | α | β | Pin Holes | Freud Code | Art. No. |
|---|---------------|---------|------------|---------|---------|----|------------|----------|---------|-------------------|--------------|------------|
| BIESSE-SELCO | | | | | | | | | | | | |
| EB 70 (L) | Main blade | 300 | 4,4 | 3 | 65 | 60 | TCG | 15° | 15° | 2/9/110 | LSB30002X | F03FS09159 |
| | HW Scorer | 200 | 4,3-5,5 | 3,2 | 65 | 36 | ATB | 8° | 15° | 2/9/100 + 2/9/110 | LI25M43PI3 | F03FS02681 |
| | HW Scorer | 300 | 4,3-5,5 | 3 | 65 | 48 | ATB | 12° | 15° | 2/9/100 + 2/9/110 | LI25M43RX3 | F03FS07616 |
| | DP Scorer | 200 | 4,3-5,1 | 3,2 | 65 | 36 | FLAT | 6° | 14° | 2/9/100 + 2/9/110 | DLI25M43PIH4 | F03FS09625 |
| | DP Scorer | 200 | 4,3-5,1 | 3,2 | 65 | 36 | FLAT | 6° | 14° | 2/9/100 + 2/9/110 | DLI25M43PIH6 | F03FS09626 |
| | Postf. scorer | 300 | 4,55 | 3,2 | 65 | 72 | ATB | 15° | 15° | 2/9/100 + 2/9/110 | LI27M DA3 | F03FS02737 |
| EB 70 (KIT 80), 75 (SEKTOR 430), 80 (SEKTOR 450), SK350, SK450 | Main blade | 320 | 4,4 | 3,2 | 65 | 60 | TCG | 15° | 15° | 2/9/110 | LSB32003X | F03FS09161 |
| | Main blade | 320 | 4,4 | 3,2 | 65 | 72 | TCG | 15° | 15° | 2/9/95 + 2/9/110 | LSB32001X | F03FS07805 |
| | HW Scorer | 200 | 4,3-5,5 | 3,2 | 65 | 36 | ATB | 8° | 15° | 2/9/100 + 2/9/110 | LI25M43PI3 | F03FS02681 |
| | HW Scorer | 300 | 4,3-5,5 | 3 | 65 | 48 | ATB | 12° | 15° | 2/9/100 + 2/9/110 | LI25M43RX3 | F03FS07616 |
| | DP Scorer | 200 | 4,3-5,1 | 3,2 | 65 | 36 | FLAT | 6° | 14° | 2/9/100 + 2/9/110 | DLI25M43PIH4 | F03FS09625 |
| | DP Scorer | 200 | 4,3-5,1 | 3,2 | 65 | 36 | FLAT | 6° | 14° | 2/9/100 + 2/9/110 | DLI25M43PIH6 | F03FS09626 |
| WN2, WN230, SK230 | Postf. scorer | 300 | 4,55 | 3,2 | 65 | 72 | ATB | 15° | 15° | 2/9/100 + 2/9/110 | LI27M DA3 | F03FS02737 |
| | Main blade | 320 | 4,4 | 3,2 | 65 | 72 | TCG | 15° | 15° | 2/9/95 + 2/9/110 | LSB32001X | F03FS07805 |
| | HW Scorer | 200 | 4,3-5,5 | 3,2 | 65 | 36 | ATB | 8° | 15° | 2/9/100 + 2/9/110 | LI25M43PI3 | F03FS02681 |
| | DP Scorer | 200 | 4,3-5,1 | 3,2 | 65 | 36 | FLAT | 6° | 14° | 2/9/100 + 2/9/110 | DLI25M43PIH4 | F03FS09625 |
| | DP Scorer | 200 | 4,3-5,1 | 3,2 | 65 | 36 | FLAT | 6° | 14° | 2/9/100 + 2/9/110 | DLI25M43PIH6 | F03FS09626 |

| Machine Type | Tool Type | D | B-B1 | b | d | Z | Tooth Type | α | β | Pin Holes | Freud Code | Art. No. |
|--------------------------------|---------------|-----|---------|-----|----|----|------------|----------|---------|-------------------------------|--------------|------------|
| | | mm | mm | mm | mm | | | | | | | |
| WN 250 | Main blade | 350 | 4,4 | 3,2 | 65 | 72 | TCG | 15° | 15° | 2/9/110 | LSB35013X | F03FS09659 |
| | HW Scorer | 200 | 4,3-5,5 | 3,2 | 65 | 36 | ATB | 8° | 15° | 2/9/100 + 2/9/110 | LI25M43PI3 | F03FS02681 |
| | DP Scorer | 200 | 4,3-5,1 | 3,2 | 65 | 36 | FLAT | 6° | 14° | 2/9/100 + 2/9/110 | DLI25M43PIH4 | F03FS09625 |
| | DP Scorer | 200 | 4,3-5,1 | 3,2 | 65 | 36 | FLAT | 6° | 14° | 2/9/100 + 2/9/110 | DLI25M43PIH6 | F03FS09626 |
| EB 95, SEKTOR 470, K470, SK370 | Main blade | 355 | 4,4 | 3,2 | 65 | 72 | TCG | 15° | 15° | 2/9/95 + 2/9/110 | LSB35508X | F03FS08740 |
| | HW Scorer | 200 | 4,3-5,5 | 3,2 | 65 | 36 | ATB | 8° | 15° | 2/9/100 + 2/9/110 | LI25M43PI3 | F03FS02681 |
| | HW Scorer | 300 | 4,3-5,5 | 3 | 65 | 48 | ATB | 12° | 15° | 2/9/100 + 2/9/110 | LI25M43RX3 | F03FS07616 |
| | DP Scorer | 200 | 4,3-5,1 | 3,2 | 65 | 36 | FLAT | 6° | 14° | 2/9/100 + 2/9/110 | DLI25M43PIH4 | F03FS09625 |
| | DP Scorer | 200 | 4,3-5,1 | 3,2 | 65 | 36 | FLAT | 6° | 14° | 2/9/100 + 2/9/110 | DLI25M43PIH6 | F03FS09626 |
| | Postf. scorer | 300 | 4,55 | 3,2 | 65 | 72 | ATB | 15° | 15° | 2/9/100 + 2/9/110 | LI27M DA3 | F03FS02737 |
| EB100 | Main blade | 360 | 4,4 | 3,2 | 65 | 72 | TCG | 15° | 15° | 2/9/95 + 2/9/110 | LSB36002X | F03FS07673 |
| | HW Scorer | 200 | 4,3-5,5 | 3,2 | 65 | 36 | ATB | 8° | 15° | 2/9/100 + 2/9/110 | LI25M43PI3 | F03FS02681 |
| | HW Scorer | 300 | 4,3-5,5 | 3 | 65 | 48 | ATB | 12° | 15° | 2/9/100 + 2/9/110 | LI25M43RX3 | F03FS07616 |
| | DP Scorer | 200 | 4,3-5,1 | 3,2 | 65 | 36 | FLAT | 6° | 14° | 2/9/100 + 2/9/110 | DLI25M43PIH4 | F03FS09625 |
| | DP Scorer | 200 | 4,3-5,1 | 3,2 | 65 | 36 | FLAT | 6° | 14° | 2/9/100 + 2/9/110 | DLI25M43PIH6 | F03FS09626 |
| | Postf. scorer | 300 | 4,55 | 3,2 | 65 | 72 | ATB | 15° | 15° | 2/9/100 + 2/9/110 | LI27M DA3 | F03FS02737 |
| WN-WNA 610, WN-WNA 610 (PFS) | Main blade | 380 | 4,4 | 3,2 | 65 | 72 | TCG | 15° | 15° | 2/9/110 | LSB38014X | F03FS09166 |
| | HW Scorer | 200 | 4,3-5,5 | 3,2 | 65 | 36 | ATB | 8° | 15° | 2/9/100 + 2/9/110 | LI25M43PI3 | F03FS02681 |
| | HW Scorer | 300 | 4,3-5,5 | 3 | 65 | 48 | ATB | 12° | 15° | 2/9/100 + 2/9/110 | LI25M43RX3 | F03FS07616 |
| | DP Scorer | 200 | 4,3-5,1 | 3,2 | 65 | 36 | FLAT | 6° | 14° | 2/9/100 + 2/9/110 | DLI25M43PIH4 | F03FS09625 |
| | DP Scorer | 200 | 4,3-5,1 | 3,2 | 65 | 36 | FLAT | 6° | 14° | 2/9/100 + 2/9/110 | DLI25M43PIH6 | F03FS09626 |
| EB108, EB110, EB120 | Main blade | 400 | 4,4 | 3,2 | 80 | 72 | TCG | 15° | 15° | 2/15/105 + 2/9/130 + 4/19/120 | LSB40009X | F03FS07810 |
| | HW Scorer | 200 | 4,3-5,5 | 3,2 | 65 | 36 | ATB | 8° | 15° | 2/9/100 + 2/9/110 | LI25M43PI3 | F03FS02681 |
| | HW Scorer | 300 | 4,3-5,5 | 3 | 65 | 48 | ATB | 12° | 15° | 2/9/100 + 2/9/110 | LI25M43RX3 | F03FS07616 |
| | DP Scorer | 200 | 4,3-5,1 | 3,2 | 65 | 36 | FLAT | 6° | 14° | 2/9/100 + 2/9/110 | DLI25M43PIH4 | F03FS09625 |
| | DP Scorer | 200 | 4,3-5,1 | 3,2 | 65 | 36 | FLAT | 6° | 14° | 2/9/100 + 2/9/110 | DLI25M43PIH6 | F03FS09626 |
| | Postf. scorer | 300 | 4,55 | 3,2 | 65 | 72 | ATB | 15° | 15° | 2/9/100 + 2/9/110 | LI27M DA3 | F03FS02737 |

| Machine Type | Tool Type | D | B-B1 | b | d | Z | Tooth Type | α | β | Pin Holes | Freud Code | Art. No. |
|------------------------------------|---------------|-----|---------|-----|----|----|------------|----------|---------|-------------------------------|--------------|------------|
| | | mm | mm | mm | mm | | | | | | | |
| WN-WNA 630, WN-WNA 630 (PFS) | Main blade | 400 | 4,4 | 3,2 | 65 | 72 | TCG | 15° | 15° | 2/9/110 | LSB40016X | F03FS09172 |
| | HW Scorer | 200 | 4,3-5,5 | 3,2 | 65 | 36 | ATB | 8° | 15° | 2/9/100 + 2/9/110 | LI25M43PI3 | F03FS02681 |
| | HW Scorer | 300 | 4,3-5,5 | 3 | 65 | 48 | ATB | 12° | 15° | 2/9/100 + 2/9/110 | LI25M43RX3 | F03FS07616 |
| | DP Scorer | 200 | 4,3-5,1 | 3,2 | 65 | 36 | FLAT | 6° | 14° | 2/9/100 + 2/9/110 | DLI25M43PIH4 | F03FS09625 |
| | DP Scorer | 200 | 4,3-5,1 | 3,2 | 65 | 36 | FLAT | 6° | 14° | 2/9/100 + 2/9/110 | DLI25M43PIH6 | F03FS09626 |
| EB/EBT 120, WN 125 | Main blade | 430 | 4,4 | 3,2 | 80 | 72 | TCG | 15° | 15° | 2/9/130 + 2/14/110 + 4/19/120 | LSB43009X | F03FS07909 |
| | HW Scorer | 200 | 4,3-5,5 | 3,2 | 65 | 36 | ATB | 8° | 15° | 2/9/100 + 2/9/110 | LI25M43PI3 | F03FS02681 |
| | HW Scorer | 300 | 4,3-5,5 | 3,2 | 65 | 72 | ATB | 12° | 15° | 2/9/100 + 2/9/110 | LI25M43RI3 | F03FS02689 |
| | DP Scorer | 200 | 4,3-5,1 | 3,2 | 65 | 36 | FLAT | 6° | 14° | 2/9/100 + 2/9/110 | DLI25M43PIH4 | F03FS09625 |
| | DP Scorer | 200 | 4,3-5,1 | 3,2 | 65 | 36 | FLAT | 6° | 14° | 2/9/100 + 2/9/110 | DLI25M43PIH6 | F03FS09626 |
| | Postf. scorer | 300 | 4,55 | 3,2 | 65 | 72 | ATB | 15° | 15° | 2/9/100 + 2/9/110 | LI27M DA3 | F03FS02737 |
| WN-WNA 650, WN-WNA 650 (PFS) | Main blade | 430 | 4,4 | 3,2 | 65 | 72 | TCG | 15° | 15° | 2/9/110 | LSB43012X | F03FS09178 |
| | HW Scorer | 200 | 4,3-5,5 | 3,2 | 65 | 36 | ATB | 8° | 15° | 2/9/100 + 2/9/110 | LI25M43PI3 | F03FS02681 |
| | HW Scorer | 300 | 4,3-5,5 | 3 | 65 | 48 | ATB | 12° | 15° | 2/9/100 + 2/9/110 | LI25M43RX3 | F03FS07616 |
| | DP Scorer | 200 | 4,3-5,1 | 3,2 | 65 | 36 | FLAT | 6° | 14° | 2/9/100 + 2/9/110 | DLI25M43PIH4 | F03FS09625 |
| | DP Scorer | 200 | 4,3-5,1 | 3,2 | 65 | 36 | FLAT | 6° | 14° | 2/9/100 + 2/9/110 | DLI25M43PIH6 | F03FS09626 |
| WN 710, WN 710 (PFS) | Main blade | 430 | 4,8 | 3,5 | 70 | 72 | TCG | 15° | 15° | 4/11/130 | LSB43013X | F03FS09180 |
| | HW Scorer | 200 | 4,7-5,9 | 3,5 | 65 | 36 | ATB | 8° | 15° | 2/9/100 + 2/9/110 | LI25M47PI3 | F03FS02720 |
| | HW Scorer | 300 | 4,7-5,9 | 3,5 | 65 | 48 | ATB | 6° | 15° | 2/9/110 | LI25M47RX3 | F03FS07744 |
| | DP Scorer | 200 | 4,7-5,5 | 3,5 | 65 | 36 | FLAT | 6° | 14° | 2/9/100 + 2/9/110 | DLI25M47PIH4 | F03FS09631 |
| | DP Scorer | 200 | 4,7-5,5 | 3,5 | 65 | 36 | FLAT | 6° | 14° | 2/9/100 + 2/9/110 | DLI25M47PIH6 | F03FS09632 |
| WN 600/132, WN 200 | Main blade | 450 | 4,8 | 3,5 | 80 | 72 | TCG | 15° | 15° | 2/14/125 + 2/9/130 + 4/19/120 | LSB45018X | F03FS07812 |
| | HW Scorer | 200 | 4,7-5,9 | 3,5 | 65 | 36 | ATB | 8° | 15° | 2/9/100 + 2/9/110 | LI25M47PI3 | F03FS02720 |
| | DP Scorer | 200 | 4,7-5,5 | 3,5 | 65 | 36 | FLAT | 6° | 14° | 2/9/100 + 2/9/110 | DLI25M47PIH4 | F03FS09631 |
| | DP Scorer | 200 | 4,7-5,5 | 3,5 | 65 | 36 | FLAT | 6° | 14° | 2/9/100 + 2/9/110 | DLI25M47PIH6 | F03FS09632 |
| | Postf. scorer | 300 | 4,95 | 3 | 65 | 72 | ATB | 15° | 15° | 2/9/100 + 2/9/110 | LI27M DB3 | F03FS02739 |

| Machine Type | Tool Type | D | B-B1 | b | d | Z | Tooth Type | α | β | Pin Holes | Freud Code | Art. No. |
|------------------------------------|---------------|-----|---------|-----|----|----|------------|----------|---------|-------------------------------------|--------------|------------|
| | | mm | mm | mm | mm | | | | | | | |
| WN 600/132, WN 200 | Main blade | 450 | 4,8 | 3,5 | 80 | 72 | TCG | 15° | 15° | 2/14/125 + 2/9/130 + 4/19/120 | LSB45018X | F03FS07812 |
| | HW Scorer | 200 | 4,7-5,9 | 3,5 | 65 | 36 | ATB | 8° | 15° | 2/9/100 + 2/9/110 | LI25M47PI3 | F03FS02720 |
| | DP Scorer | 200 | 4,7-5,5 | 3,5 | 65 | 36 | FLAT | 6° | 14° | 2/9/100 + 2/9/110 | DLI25M47PIH4 | F03FS09631 |
| | DP Scorer | 200 | 4,7-5,5 | 3,5 | 65 | 36 | FLAT | 6° | 14° | 2/9/100 + 2/9/110 | DLI25M47PIH6 | F03FS09632 |
| | Postf. scorer | 300 | 4,95 | 3 | 65 | 72 | ATB | 15° | 15° | 2/9/100 + 2/9/110 | LI27M DB3 | F03FS02739 |
| WN-WNA 730, WN-WNA 730 (PFS) | Main blade | 470 | 4,8 | 3,5 | 70 | 72 | TCG | 15° | 15° | 4/11/130 | LSB47005X | F03FS09185 |
| | HW Scorer | 200 | 4,7-5,9 | 3,5 | 65 | 36 | ATB | 8° | 15° | 2/9/100 + 2/9/110 | LI25M47PI3 | F03FS02720 |
| | HW Scorer | 300 | 4,7-5,9 | 3,5 | 65 | 48 | ATB | 6° | 15° | 2/9/110 | LI25M47RX3 | F03FS07744 |
| | DP Scorer | 200 | 4,7-5,5 | 3,5 | 65 | 36 | FLAT | 6° | 14° | 2/9/100 + 2/9/110 | DLI25M47PIH4 | F03FS09631 |
| | DP Scorer | 200 | 4,7-5,5 | 3,5 | 65 | 36 | FLAT | 6° | 14° | 2/9/100 + 2/9/110 | DLI25M47PIH6 | F03FS09632 |
| WN-WNA 750, WN-WNA 750 (PFS) | Main blade | 470 | 4,8 | 3,5 | 70 | 72 | TCG | 15° | 15° | 4/11/130 | LSB47005X | F03FS09185 |
| | Main blade | 520 | 4,8 | 3,5 | 70 | 72 | TCG | 15° | 15° | 4/11/130 | LSB52006X | F03FS09193 |
| | HW Scorer | 200 | 5,7-6,9 | 3,5 | 65 | 36 | ATB | 8° | 15° | 2/9/110 | LI25M57PI3BS | F03FS08165 |
| WN 600/145, WN 512 | Main blade | 480 | 4,8 | 3,5 | 80 | 72 | TCG | 15° | 15° | 2/9/130 + 4/19/120 | LSB48001X | F03FS09188 |
| | HW Scorer | 200 | 4,7-5,9 | 3,5 | 65 | 36 | ATB | 8° | 15° | 2/9/100 + 2/9/110 | LI25M47PI3 | F03FS02720 |
| | DP Scorer | 200 | 4,7-5,5 | 3,5 | 65 | 36 | FLAT | 6° | 14° | 2/9/100 + 2/9/110 | DLI25M47PIH4 | F03FS09631 |
| | DP Scorer | 200 | 4,7-5,5 | 3,5 | 65 | 36 | FLAT | 6° | 14° | 2/9/100 + 2/9/110 | DLI25M47PIH6 | F03FS09632 |
| | Postf. scorer | 300 | 4,55 | 3,2 | 65 | 72 | ATB | 15° | 15° | 2/9/100 + 2/9/110 | LI27M DA3 | F03FS02737 |
| WNA600/162 | Main blade | 510 | 4,8 | 3,5 | 80 | 72 | TCG | 15° | 15° | 2/9/130 + 4/19/120 | LSB51001X | F03FS09984 |
| | HW Scorer | 200 | 4,7-5,9 | 3,5 | 65 | 36 | ATB | 8° | 15° | 2/9/100 + 2/9/110 | LI25M47PI3 | F03FS02720 |
| | DP Scorer | 200 | 4,7-5,5 | 3,5 | 65 | 36 | FLAT | 6° | 14° | 2/9/100 + 2/9/110 | DLI25M47PIH4 | F03FS09631 |
| | DP Scorer | 200 | 4,7-5,5 | 3,5 | 65 | 36 | FLAT | 6° | 14° | 2/9/100 + 2/9/110 | DLI25M47PIH6 | F03FS09632 |
| | Postf. scorer | 300 | 4,95 | 3 | 65 | 72 | ATB | 15° | 15° | 2/9/100 + 2/9/110 | LI27M DB3 | F03FS02739 |
| WN-WNA 850 | Main blade | 600 | 5,8 | 4 | 70 | 60 | TCG | 15° | 15° | 4/11/130 | LSB60004X | F03FS10258 |
| | Main blade | 600 | 5,8 | 4 | 75 | 60 | TCG | 15° | 15° | 4/6,5/130 + 4/11/130 | LSB60006X | F03FS10259 |
| | HW Scorer | 200 | 5,7-6,9 | 3,5 | 65 | 36 | ATB | 8° | 15° | 2/9/110 | LI25M57PI3BS | F03FS08165 |

| Machine Type | Tool Type | D | B-B1 | b | d | Z | Tooth Type | α | β | Pin Holes | Freud Code | Art. No. |
|---------------------|------------|------------|---------|-----|-----|----|------------|----------|---------|----------------------------|------------|------------|
| | | mm | mm | mm | mm | | | | | | | |
| AES | | | | | | | | | | | | |
| ALPHA PS-03 | Main blade | 320 | 4,4 | 3,2 | 30 | 72 | TCG | 15° | 15° | 2/10/60 + 2/13/94 | LSB32009X | F03FS10296 |
| | HW Scorer | 200 | 4,3-5,5 | 3,2 | 20 | 36 | ATB | 8° | 15° | 2/10/60 + 2/9/62 + 2/11/66 | LI25M43PA3 | F03FS02670 |
| ALPHA PS-05 | Main blade | 430 | 4,4 | 3,2 | 30 | 72 | TCG | 15° | 15° | 2/13/94 | LSB43007X | F03FS09177 |
| | HW Scorer | 200 | 4,3-5,5 | 3,2 | 20 | 36 | ATB | 8° | 15° | 2/11/66 + 2/10/60 + 2/9/62 | LI25M43PA3 | F03FS02670 |
| ALPHA PS-06 | Main blade | 460 | 4,4 | 3,2 | 30 | 72 | TCG | 15° | 15° | 2/13/94 | LSB46001X | F03FS08922 |
| | HW Scorer | 200 | 4,3-5,5 | 3,2 | 20 | 36 | ATB | 8° | 15° | 2/11/66 + 2/10/60 + 2/9/62 | LI25M43PA3 | F03FS02670 |
| ANTHON | | | | | | | | | | | | |
| LN (90) | Main blade | 400 | 4,4 | 3,2 | 60 | 72 | TCG | 15° | 15° | 2/14/100 + 2/11/85 | LSB40017X | F03FS09272 |
| | HW Scorer | 180 | 4,3-5,5 | 3,2 | 20 | 28 | ATB | 8° | 15° | - | LI25M43NA3 | F03FS02661 |
| | HW Scorer | 180 | 4,3-5,5 | 3,2 | 20 | 36 | ATB | 8° | 15° | - | LI25M43XA3 | F03FS06372 |
| PORTA 100 | Main blade | 400 | 4,4 | 3,2 | 60 | 72 | TCG | 15° | 15° | 2/14/100 + 2/11/85 | LSB40017X | F03FS09272 |
| | HW Scorer | 180 | 4,3-5,5 | 3,2 | 20 | 36 | ATB | 8° | 15° | - | LI25M43XA3 | F03FS06372 |
| LNA (100), LN (120) | Main blade | 450 | 4,4 | 3,2 | 60 | 72 | TCG | 15° | 15° | 2/14/125 | LSB45008X | F03FS09182 |
| | HW Scorer | 180 | 4,3-5,5 | 3,2 | 20 | 36 | ATB | 8° | 15° | - | LI25M43XA3 | F03FS06372 |
| PORTA 150 | Main blade | 500 | 4,8 | 3,5 | 60 | 60 | TCG | 15° | 15° | 2/11/115 | LSB50009X | F03FS09189 |
| | HW Scorer | 180 | 4,3-5,5 | 3,2 | 20 | 36 | ATB | 8° | 15° | - | LI25M43XA3 | F03FS06372 |
| AYZA MIZRAK | | | | | | | | | | | | |
| LANZA P3 | Main blade | 320 | 4,4 | 3,2 | 65 | 60 | TCG | 15° | 15° | 2/9/110 | LSB32003X | F03FS09161 |
| | Main blade | 320 | 4,4 | 3,2 | 65 | 72 | TCG | 15° | 15° | 2/9/95 + 2/9/110 | LSB32001X | F03FS07805 |
| | HW Scorer | 200 | 4,3-5,5 | 3,2 | 65 | 36 | ATB | 8° | 15° | 2/9/100 + 2/9/110 | LI25M43PI3 | F03FS02681 |
| | Main blade | 360 | 4,4 | 3,2 | 65 | 60 | TCG | 15° | 15° | 2/9/110 | LSB36001X | F03FS10227 |
| | Main blade | 360 | 4,4 | 3,2 | 65 | 72 | TCG | 15° | 15° | 2/9/95 + 2/9/110 | LSB36002X | F03FS07673 |
| | HW Scorer | 200 | 4,3-5,5 | 3,2 | 65 | 36 | ATB | 8° | 15° | 2/9/100 + 2/9/110 | LI25M43PI3 | F03FS02681 |
| | LANZA P4 | Main blade | 380 | 4,4 | 3,2 | 65 | 72 | TCG | 15° | 15° | 2/9/110 | LSB38014X |
| HW Scorer | | 200 | 4,3-5,5 | 3,2 | 65 | 36 | ATB | 8° | 15° | 2/9/100 + 2/9/110 | LI25M43PI3 | F03FS02681 |
| LANZA P5 | Main blade | 400 | 4,4 | 3,2 | 65 | 72 | TCG | 15° | 15° | 2/9/110 | LSB40016X | F03FS09172 |
| | HW Scorer | 200 | 4,3-5,5 | 3,2 | 65 | 36 | ATB | 8° | 15° | 2/9/100 + 2/9/110 | LI25M43PI3 | F03FS02681 |
| LANZA P5 CARRERA | Main blade | 400 | 4,4 | 3,2 | 65 | 72 | TCG | 15° | 15° | 2/9/110 | LSB40016X | F03FS09172 |
| | HW Scorer | 200 | 4,3-5,5 | 3,2 | 65 | 36 | ATB | 8° | 15° | 2/9/100 + 2/9/110 | LI25M43PI3 | F03FS02681 |

AES - ANTHON
AYZA MIZRAKELDER
MAYER
FIMAL
GIBENHOLZER
HOLZMAHOMAG
NANXINGNIMAC
SCHEER
SCHELLINGSCM-GABBANI
TÖRK MAKINE
TURANLARLSB X RANGE
BY DIAMETER

| Machine Type | Tool Type | D | B-B1 | b | d | Z | Tooth Type | α | β | Pin Holes | Freud Code | Art. No. |
|----------------------------|------------|-----|---------|-----|----|----|------------|----------|---------|-------------------|------------|------------|
| | | mm | mm | mm | mm | mm | | mm | | | | |
| FELDER MAYER | | | | | | | | | | | | |
| KAPPA AUTOMATIC 80 | Main blade | 320 | 4,4 | 3,2 | 30 | 60 | TCG | 15° | 15° | 2/10/60 | LSB32005X | F03FS09160 |
| | Main blade | 320 | 4,4 | 3,2 | 30 | 72 | TCG | 15° | 15° | 2/10/60 + 2/13/94 | LSB32009X | F03FS10296 |
| | HW Scorer | 150 | 4,3-5,6 | 3,2 | 30 | 36 | ATB | 8° | 15° | - | LI25M43KC3 | F03FS02649 |
| KAPPA AUTOMATIC 80 EDITION | Main blade | 320 | 4,4 | 3,2 | 30 | 60 | TCG | 15° | 15° | 2/10/60 | LSB32005X | F03FS09160 |
| | HW Scorer | 150 | 4,3-5,6 | 3,2 | 30 | 36 | ATB | 8° | 15° | - | LI25M43KC3 | F03FS02649 |
| KAPPA AUTOMATIC CLASSIC | Main blade | 320 | 4,4 | 3,2 | 30 | 60 | TCG | 15° | 15° | 2/10/60 | LSB32005X | F03FS09160 |
| | HW Scorer | 150 | 4,3-5,6 | 3,2 | 30 | 36 | ATB | 8° | 15° | - | LI25M43KC3 | F03FS02649 |
| PS80 | Main blade | 320 | 4,4 | 3,2 | 30 | 60 | TCG | 15° | 15° | 2/10/60 | LSB32005X | F03FS09160 |
| | HW Scorer | 150 | 4,3-5,6 | 3,2 | 30 | 36 | ATB | 8° | 15° | - | LI25M43KC3 | F03FS02649 |
| KAPPA AUTOMATIC 100 | Main blade | 355 | 4,4 | 3,2 | 30 | 72 | TCG | 15° | 15° | 2/10/60 | LSB35504X | F03FS07674 |
| | HW Scorer | 150 | 4,3-5,6 | 3,2 | 30 | 36 | ATB | 8° | 15° | - | LI25M43KC3 | F03FS02649 |
| PS80 PREMIUM | Main blade | 355 | 4,4 | 3,2 | 30 | 72 | TCG | 15° | 15° | 2/10/60 | LSB35504X | F03FS07674 |
| | HW Scorer | 150 | 4,3-5,6 | 3,2 | 30 | 36 | ATB | 8° | 15° | - | LI25M43KC3 | F03FS02649 |
| KAPPA AUTOMATIC 120 | Main blade | 400 | 4,4 | 3,2 | 30 | 48 | TCG | 15° | 15° | 2/10/60 | LSB40001X | F03FS09168 |
| | Main blade | 400 | 4,4 | 3,2 | 30 | 60 | TCG | 15° | 15° | 2/10/60 | LSB40004X | F03FS09169 |
| | Main blade | 400 | 4,4 | 3,2 | 30 | 72 | TCG | 15° | 15° | 2/10/60 + 2/13/94 | LSB40007X | F03FS07725 |
| | HW Scorer | 150 | 4,3-5,6 | 3,2 | 30 | 36 | ATB | 8° | 15° | - | LI25M43KC3 | F03FS02649 |
| PS100 | Main blade | 400 | 4,4 | 3,2 | 30 | 48 | TCG | 15° | 15° | 2/10/60 | LSB40001X | F03FS09168 |
| | Main blade | 400 | 4,4 | 3,2 | 30 | 60 | TCG | 15° | 15° | 2/10/60 | LSB40004X | F03FS09169 |
| | Main blade | 400 | 4,4 | 3,2 | 30 | 72 | TCG | 15° | 15° | 2/10/60 + 2/13/94 | LSB40007X | F03FS07725 |
| | HW Scorer | 150 | 4,3-5,6 | 3,2 | 30 | 36 | ATB | 8° | 15° | - | LI25M43KC3 | F03FS02649 |
| PS2 Z | Main blade | 450 | 4,4 | 3,2 | 30 | 72 | TCG | 15° | 15° | 2/10/60 + 2/14/95 | LSB45007X | F03FS09181 |
| | HW Scorer | 150 | 4,3-5,6 | 3,2 | 30 | 36 | ATB | 8° | 15° | - | LI25M43KC3 | F03FS02649 |
| KAPPA AUTOMATIC 140 | Main blade | 450 | 4,4 | 3,2 | 30 | 72 | TCG | 15° | 15° | 2/10/60 + 2/14/95 | LSB45007X | F03FS09181 |
| | HW Scorer | 150 | 4,3-5,6 | 3,2 | 30 | 36 | ATB | 8° | 15° | - | LI25M43KC3 | F03FS02649 |
| FIMAL | | | | | | | | | | | | |
| CONCEPT 350 | Main blade | 350 | 4,4 | 3,2 | 30 | 72 | TCG | 15° | 15° | 2/10/60 | LSB35003X | F03FS07630 |
| | Main blade | 300 | 4,4 | 3 | 30 | 60 | TCG | 15° | 15° | 2/10/60 | LSB30001X | F03FS07802 |
| KR32 | Main blade | 350 | 4,4 | 3,2 | 30 | 72 | TCG | 15° | 15° | 2/10/60 | LSB35003X | F03FS07630 |
| KR43 | Main blade | 350 | 4,4 | 3,2 | 30 | 72 | TCG | 15° | 15° | 2/10/60 | LSB35003X | F03FS07630 |

| Machine Type | Tool Type | D | B-B1 | b | d | Z | Tooth Type | α | β | Pin Holes | Freud Code | Art. No. |
|------------------------------------|---------------|-----|---------|-----|----|----|------------|----------|---------|-------------------------------|--------------|------------|
| | | mm | mm | mm | mm | | | | | | | |
| GIBEN | | | | | | | | | | | | |
| MK, GAMMA, N, ST, SE, TREND | Main blade | 355 | 4,4 | 3,2 | 75 | 72 | TCG | 15° | 15° | 4/15/105 + 2/7/110 | LSB35505X | F03FS07633 |
| | HW Scorer | 125 | 4,3-5,5 | 3,2 | 45 | 24 | ATB | 0° | 15° | - | LI25M43FE3 | F03FS02645 |
| SMART SP105, ICON 105 | Main blade | 380 | 4,4 | 3,2 | 50 | 72 | TCG | 15° | 15° | 4/13/80 | LSB38008X | F03FS09165 |
| | HW Scorer | 250 | 4,3-5,5 | 3,2 | 50 | 48 | ATB | 8° | 15° | 3/13/80 | LI25M430F3 | F03FS02669 |
| G 2000 STARMATIC | Main blade | 400 | 4,4 | 3,2 | 75 | 72 | TCG | 15° | 15° | 4/15/105 + 2/7/110 + 2/14/100 | LSB40008X | F03FS07726 |
| | Main blade | 400 | 4,4 | 3,2 | 75 | 84 | TCG | 15° | 15° | 4/15/105 + 2/7/110 | LSB40019X | F03FS08990 |
| | HW Scorer | 125 | 4,5-5,7 | 3 | 45 | 24 | ATB | 0° | 15° | - | LI25M45FE3 | F03FS02699 |
| PRISMATIC 101 | Main blade | 400 | 4,4 | 3,2 | 75 | 72 | TCG | 15° | 15° | 4/15/105 + 2/7/110 + 2/14/100 | LSB40008X | F03FS07726 |
| | HW Scorer | 160 | 4,3-5,5 | 3,2 | 45 | 36 | ATB | 8° | 15° | 03/11/70 | LI25M43LE3 | F03FS02655 |
| PRISMATIC 201 | Main blade | 400 | 4,4 | 3,2 | 75 | 72 | TCG | 15° | 15° | 4/15/105 + 2/7/110 + 2/14/100 | LSB40008X | F03FS07726 |
| | HW Scorer | 215 | 4,3-5,5 | 3,2 | 50 | 42 | ATB | 8° | 15° | 2/7/80 + 3/15/80 | LI25M430F3 | F03FS02685 |
| | HW Scorer | 300 | 4,3-5,5 | 3,5 | 50 | 48 | ATB | 12° | 15° | 3/15/80 | LI25M43RM3 | F03FS02693 |
| | DP Scorer | 215 | 4,3-5,1 | 3,2 | 50 | 42 | FLAT | 6° | 14° | 2/7/80 + 3/15/80 | DLI25M43QFH4 | F03FS09633 |
| | DP Scorer | 215 | 4,3-5,1 | 3,2 | 50 | 42 | FLAT | 6° | 14° | 2/7/80 + 3/15/80 | DLI25M43QFH6 | F03FS09634 |
| | Postf. Scorer | 300 | 4,55 | 3,2 | 50 | 72 | ATB | 15° | 15° | 3/15/80 | LI27M DD3 | F03FS02743 |
| | Main blade | 470 | 4,4 | 3,2 | 75 | 96 | TCG | 15° | 15° | 4/15/105 | LSB47004X | F03FS09184 |
| PRISMATIC 2, 3 | HW Scorer | 215 | 4,3-5,5 | 3,2 | 50 | 42 | ATB | 8° | 15° | 2/7/80 + 3/15/80 | LI25M430F3 | F03FS02685 |
| | HW Scorer | 215 | 4,5-5,7 | 3,2 | 50 | 42 | ATB | 8° | 15° | 3/15/80 | LI25M45PF3 | F03FS02713 |
| | HW Scorer | 300 | 4,3-5,5 | 3,5 | 50 | 48 | ATB | 12° | 15° | 3/15/80 | LI25M43RM3 | F03FS02693 |
| | DP Scorer | 215 | 4,3-5,1 | 3,2 | 50 | 42 | FLAT | 6° | 14° | 2/7/80 + 3/15/80 | DLI25M43QFH4 | F03FS09633 |
| | DP Scorer | 215 | 4,3-5,1 | 3,2 | 50 | 42 | FLAT | 6° | 14° | 2/7/80 + 3/15/80 | DLI25M43QFH6 | F03FS09634 |
| | Postf. Scorer | 300 | 4,55 | 3,2 | 50 | 72 | ATB | 15° | 15° | 3/15/80 | LI27M DD3 | F03FS02743 |
| | Main blade | 530 | 4,8 | 3,5 | 75 | 72 | TCG | 15° | 15° | 2/7/110 | LSB53004X | F03FS09651 |
| ICONFAST LM D-816 | HW Scorer | 215 | 4,7-5,9 | 3,5 | 50 | 42 | ATB | 8° | 15° | 2/7/80 | LI25M47QF3 | F03FS09650 |

FELDER
MAYER
GIBEN

HOLZER
HOLZMA

HOMAG
NANXING

NIMAC
SCHEER
SCHELLING

SCM-GABRIANI
TORK MAKINE
TURANLAR

LSB X RANGE
BY DIAMETER

| Machine Type | Tool Type | D mm | B-B1 mm | b mm | d mm | Z | Tooth Type | α | β | Pin Holes | Freud Code | Art. No. |
|-------------------------------------|---------------|---------|------------|---------|---------|----|------------|----------|---------|-------------------|--------------|------------|
| HOLZHER | | | | | | | | | | | | |
| CUT 85, 82 | Main blade | 350 | 4,4 | 3,2 | 30 | 72 | TCG | 15° | 15° | 2/10/60 | LSB35003X | F03FS07630 |
| | HW Scorer | 180 | 4,3-5,5 | 3,2 | 30 | 28 | ATB | 8° | 15° | 2/7/42 + 2/10/60 | LI25M43NC3 | F03FS02663 |
| | HW Scorer | 180 | 4,3-5,5 | 3,2 | 30 | 36 | ATB | 8° | 15° | 2/7/42 + 2/10/60 | LI25M43XN3 | F03FS06373 |
| | Postf. scorer | 250 | 4,6 | 3,0 | 30 | 48 | ATB | 15° | 15° | - | LI27M BA3 | F03FS02734 |
| TECTRA 6120 CLASSIC | Main blade | 350 | 4,4 | 3,2 | 30 | 72 | TCG | 15° | 15° | 2/10/60 | LSB35003X | F03FS07630 |
| | HW Scorer | 180 | 4,3-5,5 | 3,2 | 30 | 36 | ATB | 8° | 15° | 2/7/42 + 2/10/60 | LI25M43XN3 | F03FS06373 |
| CUT 110 | Main blade | 400 | 4,4 | 3,2 | 30 | 72 | TCG | 15° | 15° | 2/10/60 + 2/13/94 | LSB40007X | F03FS07725 |
| | HW Scorer | 250 | 4,3-5,5 | 3,2 | 30 | 48 | CON | 8° | 15° | 2/10/60 | LI25M43OC3 | F03FS02668 |
| | Postf. scorer | 250 | 4,6 | 3,0 | 30 | 48 | ATB | 15° | 15° | - | LI27M BA3 | F03FS02734 |
| ZENTREX 6220 (POWER, LIFT, DYNAMIC) | Main blade | 430 | 4,4 | 3,2 | 30 | 72 | TCG | 15° | 15° | 2/13/94 | LSB43007X | F03FS09177 |
| | HW Scorer | 180 | 4,3-5,5 | 3,2 | 30 | 36 | ATB | 8° | 15° | 2/7/42 + 2/10/60 | LI25M43XN3 | F03FS06373 |
| HOLZMA | | | | | | | | | | | | |
| HPP130 | Main blade | 300 | 4,4 | 3,2 | 60 | 72 | TCG | 15° | 15° | 2/14/100 | LSB30012X | F03FS09207 |
| | DP Scorer | 180 | 4,3-5,1 | 3,2 | 45 | 30 | FLAT | 6° | 14° | - | DLI25M43NEH4 | F03FS09621 |
| | DP Scorer | 180 | 4,3-5,1 | 3,2 | 45 | 30 | FLAT | 6° | 14° | - | DLI25M43NEH6 | F03FS09622 |
| | HW Scorer | 180 | 4,3-5,5 | 3,2 | 45 | 36 | CON | 8° | 15° | - | LI25M43NE3 | F03FS02664 |
| HPP230, 250 (before 06/2014) | Main blade | 300 | 4,4 | 3,2 | 60 | 72 | TCG | 15° | 15° | 2/14/100 | LSB30012X | F03FS09207 |
| | Main blade | 350 | 4,4 | 3,2 | 60 | 72 | TCG | 15° | 15° | 2/14/100 | LSB35004X | F03FS07636 |
| | HW Scorer | 200 | 4,3-5,5 | 3,2 | 45 | 36 | ATB | 8° | 15° | - | LI25M43PE3 | F03FS02676 |
| | HW Scorer | 180 | 4,3-5,5 | 3,2 | 45 | 36 | ATB | 8° | 15° | - | LI25M43NE3 | F03FS02664 |
| | DP Scorer | 180 | 4,3-5,1 | 3,2 | 45 | 30 | FLAT | 6° | 14° | - | DLI25M43NEH4 | F03FS09621 |
| | DP Scorer | 180 | 4,3-5,1 | 3,2 | 45 | 30 | FLAT | 6° | 14° | - | DLI25M43NEH6 | F03FS09622 |
| SAWTEQ B-200 | Main blade | 310 | 4,4 | 3,2 | 60 | 72 | TCG | 15° | 15° | 2/14/100 | LSB31001X | F03FS09949 |
| | HW Scorer | 200 | 4,3-5,5 | 3,2 | 45 | 36 | ATB | 8° | 15° | - | LI25M43PE3 | F03FS02676 |
| HPP350 | Main blade | 350 | 4,4 | 3,2 | 75 | 72 | TCG | 15° | 15° | - | LSB35008X | F03FS07634 |
| | HW Scorer | 180 | 4,3-5,5 | 3,2 | 45 | 36 | ATB | 8° | 15° | - | LI25M43NE3 | F03FS02664 |
| | DP Scorer | 180 | 4,3-5,1 | 3,2 | 45 | 30 | FLAT | 6° | 14° | - | DLI25M43NEH4 | F03FS09621 |
| | DP Scorer | 180 | 4,3-5,1 | 3,2 | 45 | 30 | FLAT | 6° | 14° | - | DLI25M43NEH6 | F03FS09622 |
| | DP Scorer | 180 | 4,3-5,1 | 3,2 | 45 | 30 | FLAT | 6° | 14° | - | DLI25M43NEH6 | F03FS09622 |

| Machine Type | Tool Type | D | B-B1 | b | d | Z | Tooth Type | α | β | Pin Holes | Freud Code | Art. No. |
|-----------------|---------------|-----|---------|-----|----|-----|------------|----------|---------|---------------------|--------------|------------|
| | | mm | mm | mm | mm | | | | | | | |
| HPP180 | Main blade | 380 | 4,4 | 3,2 | 60 | 72 | TCG | 15° | 15° | 2/14/100 | LSB38002X | F03FS07631 |
| | HW Scorer | 180 | 4,3-5,5 | 3,2 | 45 | 36 | ATB | 8° | 15° | - | LI25M43NE3 | F03FS02664 |
| | DP Scorer | 180 | 4,3-5,1 | 3,2 | 45 | 30 | FLAT | 6° | 14° | - | DLI25M43NEH4 | F03FS09621 |
| | DP Scorer | 180 | 4,3-5,1 | 3,2 | 45 | 30 | FLAT | 6° | 14° | - | DLI25M43NEH6 | F03FS09622 |
| HPP380, 82 | Main blade | 380 | 4,4 | 3,2 | 60 | 72 | TCG | 15° | 15° | 2/14/100 | LSB38002X | F03FS07631 |
| | Main blade | 380 | 4,8 | 3,5 | 60 | 72 | TCG | 15° | 15° | 2/14/100 | LSB38004X | F03FS07632 |
| | Main blade | 380 | 4,8 | 3,5 | 60 | 84 | TCG | 15° | 15° | 2/14/100 | LSB38005X | F03FS07807 |
| | HW Scorer | 180 | 4,3-5,5 | 3,2 | 45 | 36 | ATB | 8° | 15° | - | LI25M43NE3 | F03FS02664 |
| | HW Scorer | 180 | 4,7-5,9 | 3,5 | 45 | 36 | ATB | 8° | 15° | - | LI25M47NE3 | F03FS02715 |
| | DP Scorer | 180 | 4,3-5,1 | 3,2 | 45 | 30 | FLAT | 6° | 14° | - | DLI25M43NEH4 | F03FS09621 |
| | DP Scorer | 180 | 4,3-5,1 | 3,2 | 45 | 30 | FLAT | 6° | 14° | - | DLI25M43NEH6 | F03FS09622 |
| | DP Scorer | 180 | 4,7-5,5 | 3,5 | 45 | 30 | FLAT | 6° | 14° | - | DLI25M47NEH4 | F03FS09623 |
| | DP Scorer | 180 | 4,7-5,5 | 3,5 | 45 | 30 | FLAT | 6° | 14° | - | DLI25M47NEH6 | F03FS09624 |
| | Postf. scorer | 280 | 5,0 | 3,5 | 45 | 84 | ATB | 15° | 15° | - | LI27M CA3 | F03FS02736 |
| HPL410 | Main blade | 420 | 4,8 | 3,5 | 60 | 60 | TCG | 15° | 15° | 2/14/125 | LSB42001X | F03FS10234 |
| | Main blade | 420 | 4,8 | 3,5 | 60 | 84 | TCG | 15° | 15° | 2/14/100 + 2/14/125 | LSB42002X | F03FS09176 |
| | HW Scorer | 180 | 4,7-5,9 | 3,5 | 45 | 36 | ATB | 8° | 15° | - | LI25M47NE3 | F03FS02715 |
| | DP Scorer | 180 | 4,7-5,5 | 3,5 | 45 | 30 | FLAT | 6° | 14° | - | DLI25M47NEH4 | F03FS09623 |
| | DP Scorer | 180 | 4,7-5,5 | 3,5 | 45 | 30 | FLAT | 6° | 14° | - | DLI25M47NEH6 | F03FS09624 |
| | Postf. scorer | 340 | 5,0 | 3,5 | 45 | 108 | ATB | 15° | 15° | 3/14/65 | LI27M EB3 | F03FS02747 |
| HPP430, 510, 11 | Main blade | 450 | 4,8 | 3,5 | 60 | 72 | TCG | 15° | 15° | 2/14/125 + 2/17/100 | LSB45017X | F03FS07391 |
| | HW Scorer | 180 | 4,7-5,9 | 3,5 | 45 | 36 | ATB | 8° | 15° | - | LI25M47NE3 | F03FS02715 |
| | DP Scorer | 180 | 4,7-5,5 | 3,5 | 45 | 30 | FLAT | 6° | 14° | - | DLI25M47NEH4 | F03FS09623 |
| | DP Scorer | 180 | 4,7-5,5 | 3,5 | 45 | 30 | FLAT | 6° | 14° | - | DLI25M47NEH6 | F03FS09624 |
| | Postf. scorer | 340 | 5,0 | 3,5 | 45 | 108 | ATB | 15° | 15° | 3/14/65 | LI27M EB3 | F03FS02747 |

HOLZER
HOLZMA

HOMAG
NANXING

NIMAC
SCHEER
SCHELLING

SCM-GAEBIANI
TÖRK MAKINE
TURANLAR

LSB X RANGE
BY DIAMETER

| Machine Type | Tool Type | D | B-B1 | b | d | Z | Tooth Type | α | β | Pin Holes | Freud Code | Art. No. |
|--------------|---------------|-----|---------|-----|----|-----|------------|----------|---------|---------------------|--------------|------------|
| | | mm | mm | mm | mm | | | | | | | |
| 22 | Main blade | 500 | 4,8 | 3,5 | 60 | 72 | TCG | 15° | 15° | 2/11/115 | LSB50011X | F03FS09191 |
| | HW Scorer | 200 | 4,7-5,9 | 3,5 | 45 | 36 | ATB | 8° | 15° | - | LI25M47PE3 | F03FS02719 |
| | DP Scorer | 200 | 4,7-5,5 | 3,5 | 45 | 36 | FLAT | 6° | 14° | - | DLI25M47PEH4 | F03FS09629 |
| | DP Scorer | 200 | 4,7-5,5 | 3,5 | 45 | 36 | FLAT | 6° | 14° | - | DLI25M47PEH6 | F03FS09630 |
| | Postf. scorer | 340 | 5,0 | 3,5 | 45 | 108 | ATB | 15° | 15° | 3/14/65 | LI27M EB3 | F03FS02747 |
| HPL550 | Main blade | 520 | 4,8 | 3,5 | 60 | 72 | TCG | 15° | 15° | 2/11/115 + 2/19/120 | LSB52003X | F03FS09192 |
| | HW Scorer | 200 | 4,7-5,9 | 3,5 | 45 | 36 | ATB | 8° | 15° | - | LI25M47PE3 | F03FS02719 |
| | DP Scorer | 200 | 4,7-5,5 | 3,5 | 45 | 36 | FLAT | 6° | 14° | - | DLI25M47PEH4 | F03FS09629 |
| | DP Scorer | 200 | 4,7-5,5 | 3,5 | 45 | 36 | FLAT | 6° | 14° | - | DLI25M47PEH6 | F03FS09630 |
| | Postf. scorer | 340 | 5,0 | 3,5 | 45 | 108 | ATB | 15° | 15° | 3/14/65 | LI27M EB3 | F03FS02747 |
| HPL570 | Main blade | 570 | 4,8 | 3,5 | 60 | 60 | TCG | 15° | 15° | 2/11/115 + 2/19/120 | LSB57001X | F03FS09199 |
| | HW Scorer | 200 | 4,7-5,9 | 3,5 | 45 | 36 | ATB | 8° | 15° | - | LI25M47PE3 | F03FS02719 |
| | DP Scorer | 200 | 4,7-5,5 | 3,5 | 45 | 36 | FLAT | 6° | 14° | - | DLI25M47PEH4 | F03FS09629 |
| | DP Scorer | 200 | 4,7-5,5 | 3,5 | 45 | 36 | FLAT | 6° | 14° | - | DLI25M47PEH6 | F03FS09630 |
| | Postf. scorer | 340 | 5,0 | 3,5 | 45 | 108 | ATB | 15° | 15° | 3/14/65 | LI27M EB3 | F03FS02747 |
| HPP42, 33 | Main blade | 600 | 5,8 | 4 | 60 | 60 | TCG | 15° | 15° | 2/11/115 + 2/19/120 | LSB60001X | F03FS09200 |
| | Main blade | 600 | 5,8 | 4 | 60 | 72 | TCG | 15° | 15° | 2/11/115 + 2/19/120 | LSB60002X | F03FS09201 |
| | HW Scorer | 200 | 5,7-6,9 | 4 | 45 | 36 | ATB | 8° | 15° | - | LI25M57PE3 | F03FS02728 |
| HOMAG | | | | | | | | | | | | |
| CH 3 | Main blade | 300 | 4,4 | 3 | 75 | 60 | TCG | 15° | 15° | - | LSB30003X | F03FS03916 |
| | HW Scorer | 125 | 4,3-5,5 | 3,2 | 45 | 24 | ATB | 0° | 15° | - | LI25M43FE3 | F03FS02645 |
| CH 3 | Main blade | 300 | 4,4 | 3 | 75 | 60 | TCG | 15° | 15° | - | LSB30003X | F03FS03916 |
| | HW Scorer | 125 | 4,3-5,5 | 3,2 | 45 | 24 | ATB | 0° | 15° | - | LI25M43FE3 | F03FS02645 |
| CT 04/40 | Main blade | 300 | 4,4 | 3 | 75 | 60 | TCG | 15° | 15° | - | LSB30003X | F03FS03916 |
| | HW Scorer | 150 | 4,3-5,6 | 3,2 | 45 | 36 | ATB | 8° | 15° | - | LI25M43KE3 | F03FS02651 |
| CV'S | Main blade | 300 | 4,4 | 3 | 75 | 60 | TCG | 15° | 15° | - | LSB30003X | F03FS10218 |
| | HW Scorer | 125 | 4,3-5,5 | 3,2 | 45 | 24 | ATB | 0° | 15° | - | LI25M43FE3 | F03FS02645 |

| Machine Type | Tool Type | D | B-B1 | b | d | Z | Tooth Type | α | β | Pin Holes | Freud Code | Art. No. |
|-------------------------------|------------|-----|---------|-----|----|----|------------|----------|---------|-------------------------------------|--------------|------------|
| | | mm | mm | mm | mm | | | | | | | |
| CH 04 | Main blade | 355 | 4,4 | 3,2 | 75 | 72 | TCG | 15° | 15° | 3/7/100 | LSB35507X | F03FS07710 |
| | HW Scorer | 180 | 4,3-5,5 | 3,2 | 45 | 36 | ATB | 8° | 15° | - | LI25M43NE3 | F03FS02664 |
| | DP Scorer | 180 | 4,3-5,1 | 3,2 | 45 | 30 | FLAT | 6° | 14° | - | DLI25M43NEH4 | F03FS09621 |
| | DP Scorer | 180 | 4,3-5,1 | 3,2 | 45 | 30 | FLAT | 6° | 14° | - | DLI25M43NEH6 | F03FS09622 |
| CH 08/12 | Main blade | 400 | 4,4 | 3,2 | 75 | 72 | TCG | 15° | 15° | 4/15/105 + 2/7/110 + 2/14/100 | LSB40008X | F03FS07726 |
| | HW Scorer | 150 | 4,3-5,6 | 3,2 | 45 | 36 | ATB | 8° | 15° | - | LI25M43KE3 | F03FS02651 |
| NANXING | | | | | | | | | | | | |
| NPC330 | Main blade | 380 | 4,4 | 3,2 | 60 | 72 | TCG | 15° | 15° | 2/14/100 | LSB38002X | F03FS07631 |
| | Main blade | 350 | 4,4 | 3,2 | 60 | 72 | TCG | 15° | 15° | 2/14/100 | LSB35004X | F03FS07636 |
| | HW Scorer | 200 | 4,3-5,5 | 3,2 | 45 | 36 | ATB | 8° | 15° | - | LI25M43PE3 | F03FS02676 |
| MJB1327B | Main blade | 450 | 4,8 | 3,5 | 60 | 72 | TCG | 15° | 15° | 2/14/125 + 2/17/100 | LSB45017X | F03FS09272 |
| | Main blade | 400 | 4,4 | 3,2 | 60 | 84 | TCG | 15° | 15° | 2/14/100 | LSB40021X | F03FS09255 |
| | HW Scorer | 180 | 4,3-5,5 | 3,2 | 30 | 36 | ATB | 8° | 15° | 2/7/42 + 2/10/60 | LI25M43XN3 | F03FS06373 |
| NP280FG NP280F | Main blade | 450 | 4,8 | 3,5 | 60 | 72 | TCG | 15° | 15° | 2/14/125 + 2/17/100 | LSB45017X | F03FS09272 |
| | Main blade | 400 | 4,4 | 3,2 | 60 | 84 | TCG | 15° | 15° | 2/14/100 | LSB40021X | F03FS09255 |
| | Main blade | 350 | 4,4 | 3,2 | 60 | 72 | TCG | 15° | 15° | 2/14/100 | LSB35004X | F03FS07636 |
| | HW Scorer | 180 | 4,3-5,5 | 3,2 | 30 | 36 | ATB | 8° | 15° | 2/7/42 + 2/10/60 | LI25M43XN3 | F03FS06373 |
| NPL330HG NP330H NP330HG | Main blade | 450 | 4,8 | 3,5 | 60 | 72 | TCG | 15° | 15° | 2/14/125 + 2/17/100 | LSB45017X | F03FS07391 |
| | HW Scorer | 180 | 4,7-5,9 | 3,5 | 45 | 36 | ATB | 8° | 15° | - | LI25M47NE3 | F03FS02715 |
| | DP Scorer | 180 | 4,7-5,5 | 3,5 | 45 | 30 | FLAT | 6° | 14° | - | DLI25M47NEH4 | F03FS09623 |
| | DP Scorer | 180 | 4,7-5,5 | 3,5 | 45 | 30 | FLAT | 6° | 14° | - | DLI25M47NEH6 | F03FS09624 |
| NP380FG NP330FG NP330F | Main blade | 450 | 4,8 | 3,5 | 60 | 72 | TCG | 15° | 15° | 2/14/125 + 2/17/100 | LSB45017X | F03FS09272 |
| | Main blade | 400 | 4,4 | 3,2 | 60 | 84 | TCG | 15° | 15° | 2/14/100 | LSB40021X | F03FS09255 |
| | HW Scorer | 180 | 4,7-5,9 | 3,5 | 45 | 36 | ATB | 8° | 15° | - | LI25M47NE3 | F03FS02715 |
| | DP Scorer | 180 | 4,7-5,5 | 3,5 | 45 | 30 | FLAT | 6° | 14° | - | DLI25M47NEH4 | F03FS09623 |
| | DP Scorer | 180 | 4,7-5,5 | 3,5 | 45 | 30 | FLAT | 6° | 14° | - | DLI25M47NEH6 | F03FS09624 |

HOMAG
NANXING

IIMAC
PANHANS
HEER
SCHELLING

SCM-GABBANI
TORK MAKINE
TURANLAR

LSB X RANGE
BY DIAMETER

| Machine Type | Tool Type | D | B-B1 | b | d | Z | Tooth Type | α | β | Pin Holes | Freud Code | Art. No. |
|---------------------------------------|---------------|-----|---------|-----|----|----|------------|----------|---------|------------------------|--------------|------------|
| | | mm | mm | mm | mm | | | | | | | |
| NZH3318 NPD380 | Main blade | 450 | 4,8 | 3,5 | 60 | 72 | TCG | 15° | 15° | 2/14/125 + 2/17/100 | LSB45017X | F03FS07391 |
| | HW Scorer | 180 | 4,7-5,9 | 3,5 | 45 | 36 | ATB | 8° | 15° | - | LI25M47NE3 | F03FS02715 |
| | DP Scorer | 180 | 4,7-5,5 | 3,5 | 45 | 30 | FLAT | 6° | 14° | - | DLI25M47NEH4 | F03FS09623 |
| | DP Scorer | 180 | 4,7-5,5 | 3,5 | 45 | 30 | FLAT | 6° | 14° | - | DLI25M47NEH6 | F03FS09624 |
| NIMAC | | | | | | | | | | | | |
| HERMES 70 CNC | Main blade | 300 | 4,4 | 3 | 65 | 72 | TCG | 15° | 15° | 2/9/95 + 2/9/110 | LSB30006X | F03FS09158 |
| | Main blade | 320 | 4,4 | 3,2 | 65 | 72 | TCG | 15° | 15° | 2/9/95 + 2/9/110 | LSB32001X | F03FS07805 |
| ATLAS 80 | Main blade | 320 | 4,4 | 3,2 | 65 | 72 | TCG | 15° | 15° | 2/9/95 + 2/9/110 | LSB32001X | F03FS07805 |
| ATLAS 100/100TL | Main blade | 355 | 4,4 | 3,2 | 65 | 72 | TCG | 15° | 15° | 2/9/95 + 2/9/110 | LSB35508X | F03FS08740 |
| | Main blade | 360 | 4,4 | 3,2 | 65 | 72 | TCG | 15° | 15° | 2/9/95 + 2/9/110 | LSB36002X | F03FS07673 |
| PANHANS | | | | | | | | | | | | |
| EURO 10 SF | Main blade | 300 | 4,4 | 3 | 30 | 60 | TCG | 15° | 15° | 2/10/60 | LSB30001X | F03FS07802 |
| | HW Scorer | 250 | 4,3-5,5 | 3,2 | 30 | 48 | CON | 8° | 15° | 2/10/60 | LI25M430C3 | F03FS02668 |
| | Postf. scorer | 250 | 4,6 | 3 | 30 | 48 | ATB | 15° | 15° | - | LI27M BA3 | F03FS02734 |
| EURO 5 (SF, COMPACT, ECOPAN) | Main blade | 300 | 4,4 | 3 | 30 | 60 | TCG | 15° | 15° | 2/10/60 | LSB30001X | F03FS07802 |
| | HW Scorer | 125 | 4,3-5,5 | 3,2 | 20 | 24 | CON | 0° | 15° | - | LI25M43FA3 | F03FS02643 |
| EURO10, 693/SH 70 | Main blade | 300 | 4,4 | 3 | 30 | 60 | TCG | 15° | 15° | 2/10/60 | LSB30001X | F03FS07802 |
| | HW Scorer | 125 | 4,3-5,5 | 3,2 | 20 | 24 | CON | 0° | 15° | - | LI25M43FA3 | F03FS02643 |
| | HW Scorer | 180 | 4,3-5,5 | 3,2 | 30 | 28 | CON | 8° | 15° | 2/7/42 + 2/10/60 | LI25M43NC3 | F03FS02663 |
| S 45 | Main blade | 300 | 4,4 | 3 | 30 | 60 | TCG | 15° | 15° | 2/10/60 | LSB30001X | F03FS07802 |
| | Main blade | 350 | 4,4 | 3,2 | 30 | 72 | TCG | 15° | 15° | 2/10/60 | LSB35003X | F03FS07630 |
| | HW Scorer | 180 | 4,3-5,5 | 3,2 | 30 | 28 | CON | 8° | 15° | 2/7/42 + 2/10/60 | LI25M43NC3 | F03FS02663 |
| EURO 12, 30 | Main blade | 350 | 4,4 | 3,2 | 30 | 72 | TCG | 15° | 15° | 2/10/60 | LSB35003X | F03FS07630 |
| | HW Scorer | 180 | 4,3-5,5 | 3,2 | 30 | 28 | CON | 8° | 15° | 2/7/42 + 2/10/60 | LI25M43NC3 | F03FS02663 |
| EURO 12 SF | Main blade | 350 | 4,4 | 3,2 | 30 | 72 | TCG | 15° | 15° | 2/10/60 | LSB35003X | F03FS07630 |
| | HW Scorer | 280 | 4,3-5,5 | 3,2 | 30 | 48 | CON | 12° | 15° | 2/10/60 | LI25M43VC3 | F03FS07419 |
| POLYPAN 47 | Main blade | 350 | 4,4 | 3,2 | 30 | 72 | TCG | 15° | 15° | 2/10/60 | LSB35003X | F03FS07630 |
| | HW Scorer | 180 | 4,3-5,5 | 3,2 | 30 | 28 | CON | 8° | 15° | 2/7/42 + 2/10/60 | LI25M43NC3 | F03FS02663 |
| | Postf. scorer | 300 | 4,55 | 3 | 30 | 72 | ATB | 15° | 15° | - | LI27M DF3 | F03FS02745 |

| Machine Type | Tool Type | D | B-B1 | b | d | Z | Tooth Type | α | β | Pin Holes | Freud Code | Art. No. |
|---|------------|-----|---------|-----|----|----|------------|----------|---------|-----------------------------|------------|------------|
| | | mm | mm | mm | mm | | | | | | | |
| EUROSTAR 2 XL, POLYSTAR | Main blade | 370 | 4,4 | 3,2 | 30 | 72 | TCG | 15° | 15° | 2/10/60 | LSC37001 | F03FS06312 |
| | HW Scorer | 180 | 4,3-5,5 | 3,2 | 30 | 28 | CON | 8° | 15° | 2/7/42 + 2/10/60 | LI25M43NC3 | F03FS02663 |
| | HW Scorer | 280 | 4,3-5,5 | 3,2 | 30 | 48 | CON | 6° | 15° | 2/10/60 | LI25M43VC3 | F03FS07419 |
| EURO 32 | Main blade | 370 | 4,4 | 3,2 | 30 | 72 | TCG | 15° | 15° | 2/10/60 | LSB37001X | F03FS10228 |
| | HW Scorer | 180 | 4,3-5,5 | 3,2 | 30 | 28 | CON | 8° | 15° | 2/7/42 + 2/10/60 | LI25M43NC3 | F03FS02663 |
| 693/SH 110 | Main blade | 400 | 4,4 | 3,2 | 30 | 72 | TCG | 15° | 15° | 2/10/60 + 2/13/94 | LSB40007X | F03FS07725 |
| | HW Scorer | 180 | 4,3-5,5 | 3,2 | 30 | 28 | CON | 8° | 15° | 2/7/42 + 2/10/60 | LI25M43NC3 | F03FS02663 |
| EUROSTAR 2 XXL | Main blade | 400 | 4,4 | 3,2 | 30 | 72 | TCG | 15° | 15° | 2/10/60 + 2/13/94 | LSB40007X | F03FS07725 |
| | HW Scorer | 180 | 4,3-5,5 | 3,2 | 30 | 28 | CON | 8° | 15° | 2/7/42 + 2/10/60 | LI25M43NC3 | F03FS02663 |
| | HW Scorer | 280 | 4,3-5,5 | 3,2 | 30 | 48 | CON | 6° | 15° | 2/10/60 | LI25M43VC3 | F03FS07419 |
| SCHEER KOCH | | | | | | | | | | | | |
| PA 6000, 5500 | Main blade | 350 | 4,4 | 3,2 | 30 | 72 | TCG | 15° | 15° | 2/10/60 | LSB35003X | F03FS07630 |
| | HW Scorer | 200 | 4,3-5,5 | 3,2 | 20 | 36 | ATB | 8° | 15° | 2/11/66 + 2/10/60 + 2/9/62 | LI25M43PA3 | F03FS02670 |
| | HW Scorer | 200 | 4,3-5,5 | 3,2 | 30 | 36 | ATB | 8° | 15° | 2/9/60 + 2/10/60 | LI25M43PC3 | F03FS02674 |
| SCHELLING | | | | | | | | | | | | |
| FH3 | Main blade | 300 | 4,4 | 3 | 30 | 72 | TCG | 15° | 15° | 2/10/60 | LSB30005X | F03FS07803 |
| | Main blade | 350 | 4,4 | 3,2 | 30 | 72 | TCG | 15° | 15° | 2/10/60 | LSB35003X | F03FS07630 |
| | HW Scorer | 180 | 4,3-5,5 | 3,2 | 30 | 36 | ATB | 8° | 15° | 2/7/42 + 2/10/60 | LI25M43XN3 | F03FS06373 |
| FH4 (till 06/2015) | Main blade | 350 | 4,4 | 3,2 | 30 | 72 | TCG | 15° | 15° | 2/10/60 | LSB35003X | F03FS07630 |
| | HW Scorer | 300 | 4,3-5,5 | 3,2 | 30 | 48 | ATB | 12° | 15° | 2/11/73 + 2/11/75 + 2/13/94 | LI25M43RC3 | F03FS07577 |
| S45 | Main blade | 350 | 4,4 | 3,2 | 30 | 72 | TCG | 15° | 15° | 2/10/60 | LSB35003X | F03FS07630 |
| | Main blade | 400 | 4,4 | 3,2 | 30 | 72 | TCG | 15° | 15° | 2/10/60 + 2/13/94 | LSB40007X | F03FS07725 |
| | HW Scorer | 180 | 4,3-5,5 | 3,2 | 30 | 36 | ATB | 8° | 15° | 2/7/42 + 2/10/60 | LI25M43XN3 | F03FS06373 |
| | HW Scorer | 300 | 4,3-5,5 | 3,2 | 30 | 48 | ATB | 12° | 15° | 2/11/73 + 2/11/75 + 2/13/94 | LI25M43RC3 | F03FS07577 |
| SCHELLING FH4 (from 07/2015 till 07/2017) | Main blade | 360 | 4,4 | 3,2 | 30 | 72 | TCG | 15° | 15° | 2/13/94 | LSB36003X | F03FS09341 |
| | HW Scorer | 200 | 4,3-5,5 | 3,2 | 20 | 36 | ATB | 8° | 15° | 2/11/66 + 2/10/60 + 2/9/62 | LI25M43PA3 | F03FS02670 |
| FH4 (from 07/2017) | Main blade | 360 | 4,4 | 3,2 | 30 | 72 | TCG | 15° | 15° | 2/13/94 | LSB36003X | F03FS09341 |
| | HW Scorer | 300 | 4,3-5,5 | 3,2 | 30 | 48 | ATB | 12° | 15° | 2/11/73 + 2/11/75 + 2/13/94 | LI25M43RC3 | F03FS07577 |
| FH5 (from 07/2015) | Main blade | 400 | 4,4 | 3,2 | 30 | 72 | TCG | 15° | 15° | 2/10/60 + 2/13/94 | LSB40007X | F03FS07725 |
| | HW Scorer | 300 | 4,3-5,5 | 3,2 | 30 | 48 | ATB | 12° | 15° | 2/11/73 + 2/11/75 + 2/13/94 | LI25M43RC3 | F03FS07577 |

| Machine Type | Tool Type | D | B-B1 | b | d | Z | Tooth Type | α | β | Pin Holes | Freud Code | Art. No. |
|---------------------------------------|------------|-----|---------|-----|----|----|------------|----------|---------|--------------------------------|------------|------------|
| | | mm | mm | mm | mm | | | | | | | |
| FH5 (from 07/2015) | Main blade | 400 | 4,4 | 3,2 | 30 | 72 | TCG | 15° | 15° | 2/10/60 + 2/13/94 | LSB40007X | F03FS07725 |
| | HW Scorer | 300 | 4,3-5,5 | 3,2 | 30 | 48 | ATB | 12° | 15° | 2/11/73 + 2/11/75 + 2/13/94 | LI25M43RC3 | F03FS07577 |
| FH5 | Main blade | 400 | 4,4 | 3,2 | 30 | 72 | TCG | 15° | 15° | 2/10/60 + 2/13/94 | LSB40007X | F03FS07725 |
| | HW Scorer | 200 | 4,3-5,5 | 3,2 | 20 | 36 | ATB | 8° | 15° | 2/11/66 + 2/10/60 + 2/9/62 | LI25M43PA3 | F03FS02670 |
| FK4 (from 07/2015) | Main blade | 400 | 4,4 | 3,2 | 30 | 72 | TCG | 15° | 15° | 2/10/60 + 2/13/94 | LSB40007X | F03FS07725 |
| | HW Scorer | 200 | 4,3-5,5 | 3,2 | 20 | 36 | ATB | 8° | 15° | 2/11/66 + 2/10/60 + 2/9/62 | LI25M43PA3 | F03FS02670 |
| FK4 (from 07/2017) | Main blade | 400 | 4,4 | 3,2 | 30 | 72 | TCG | 15° | 15° | 2/10/60 + 2/13/94 | LSB40007X | F03FS07725 |
| | HW Scorer | 300 | 4,3-5,5 | 3,2 | 30 | 48 | ATB | 12° | 15° | 2/11/73 + 2/11/75 + 2/13/94 | LI25M43RC3 | F03FS07577 |
| FH6, AH6, CH6 (till 06/2015) | Main blade | 460 | 4,4 | 3,2 | 30 | 72 | TCG | 15° | 15° | 2/13/94 | LSB46001X | F03FS08922 |
| | HW Scorer | 200 | 4,3-5,5 | 3,2 | 20 | 36 | ATB | 8° | 15° | 2/11/66 + 2/10/60 + 2/9/62 | LI25M43PA3 | F03FS02670 |
| FK6, FP6, FM6 | Main blade | 460 | 4,4 | 3,2 | 30 | 72 | TCG | 15° | 15° | 2/13/94 | LSB46001X | F03FS08922 |
| | HW Scorer | 200 | 4,3-5,5 | 3,2 | 20 | 36 | ATB | 8° | 15° | 2/11/66 + 2/10/60 + 2/9/62 | LI25M43PA3 | F03FS02670 |
| FH6, AH6, CH6 (starting from 07/2015) | Main blade | 480 | 4,8 | 3,5 | 30 | 72 | TCG | 15° | 15° | 2/10/60 + 2/13/94 | LSB48004X | F03FS09187 |
| | HW Scorer | 220 | 4,7-5,9 | 3,5 | 20 | 36 | ATB | 8° | 15° | 2/9/62 | LI25M47UA3 | F03FS09266 |
| | HW Scorer | 200 | 4,7-5,9 | 3,5 | 20 | 36 | ATB | 8° | 15° | 2/11/66 | LI25M47PA3 | F03FS02716 |
| FL | Main blade | 480 | 4,4 | 3,2 | 30 | 72 | TCG | 15° | 15° | 2/10/60 + 2/13/94 | LSB48007X | F03FS09914 |
| | HW Scorer | 200 | 4,3-5,5 | 3,2 | 20 | 36 | ATB | 8° | 15° | 2/11/66 + 2/10/60 + 2/9/62 | LI25M43PA3 | F03FS02670 |
| FH8, AH8, CH8 | Main blade | 520 | 4,8 | 3,5 | 30 | 72 | TCG | 15° | 15° | 2/13/94 | LSB52007X | F03FS09319 |
| | Main blade | 520 | 4,4 | 3,2 | 30 | 72 | TCG | 15° | 15° | 2/13/94 | LSB52008X | F03FS09319 |
| | HW Scorer | 200 | 4,3-5,5 | 3,2 | 20 | 36 | ATB | 8° | 15° | 2/11/66 + 2/10/60 + 2/9/62 | LI25M43PA3 | F03FS02670 |
| | HW Scorer | 220 | 4,7-5,9 | 3,5 | 20 | 36 | ATB | 8° | 15° | 2/9/62 | LI25M47UA3 | F03FS09266 |
| FK8, FM8 | HW Scorer | 200 | 4,7-5,9 | 3,5 | 20 | 36 | ATB | 8° | 15° | 2/11/66 | LI25M47PA3 | F03FS02716 |
| | Main blade | 520 | 4,8 | 3,5 | 30 | 72 | TCG | 15° | 15° | 2/13/94 | LSB52007X | F03FS09319 |
| | HW Scorer | 200 | 4,7-5,9 | 3,5 | 20 | 36 | ATB | 8° | 15° | 2/11/66 | LI25M47PA3 | F03FS02716 |
| | Main blade | 520 | 4,4 | 3,2 | 30 | 72 | TCG | 15° | 15° | 2/13/94 | LSB52008X | F03FS09319 |
| FK10, FM10 | HW Scorer | 200 | 4,3-5,5 | 3,2 | 30 | 36 | ATB | 8° | 15° | 2/11/66 + 2/10/60 + 2/9/62 | LI25M43PA3 | F03FS02670 |
| | Main blade | 680 | 6,2 | 4,2 | 40 | 60 | TCG | 18° | 13° | 2/13/140 + 2/17/140 + 2/13/114 | LSB68001X | F03FS09203 |
| ASH (FSM) | HW Scorer | 200 | 6,1-7,3 | 4 | 20 | 36 | ATB | 8° | 15° | 2/11/66 | LI25M61PA3 | F03FS02730 |
| | Main blade | 720 | 6,4 | 4,4 | 40 | 60 | TCG | 18° | 13° | 2/14/114 + 2/14/140 | LSB72001X | F03FS09204 |
| | HW Scorer | 220 | 6,3-7,5 | 4,4 | 20 | 36 | ATB | 8° | 15° | 2/11/66 | LI25M63UA3 | F03FS02732 |

| Machine Type | Tool Type | D | B-B1 | b | d | Z | Tooth Type | α | β | Pin Holes | Freud Code | Art. No. |
|--------------------------------|---------------|-----|---------|-----|----|----|------------|----------|---------|---|--------------|------------|
| | | mm | mm | mm | mm | | | | | | | |
| SCM | | | | | | | | | | | | |
| PRIMA 50 | Main blade | 300 | 4,4 | 3 | 80 | 60 | TCG | 15° | 15° | 4/9/100 + 2/14/110 | LSB30004X | F03FS09157 |
| | Main blade | 300 | 4,4 | 3 | 80 | 72 | TCG | 15° | 15° | 4/9/100 + 2/14/110 | LSB30008X | F03FS07804 |
| | HW Scorer | 160 | 4,3-5,5 | 3,2 | 55 | 36 | ATB | 8° | 15° | 3/6/84 + 3/7/66 | LI25M43LG3 | F03FS02657 |
| PRIMA 67 | Main blade | 320 | 4,4 | 3,2 | 80 | 60 | TCG | 10° | 15° | 4/9/100 + 2/9/110 + 2/14/110 | LSB32006X | F03FS10101 |
| | HW Scorer | 160 | 4,3-5,5 | 3,2 | 55 | 36 | ATB | 8° | 15° | 3/6/84 + 3/7/66 | LI25M43LG3 | F03FS02657 |
| | Postf. scorer | 280 | 4,65 | 3,2 | 80 | 72 | ATB | 15° | 15° | 2/14/110 | LI27M47VL3 | F03FS08014 |
| IMPACT 85 K | Main blade | 350 | 4,4 | 3,2 | 80 | 72 | TCG | 15° | 15° | 4/9/100 + 2/9/110 + 2/14/110 | LSB35005X | F03FS07635 |
| | HW Scorer | 160 | 4,3-5,5 | 3,2 | 55 | 36 | ATB | 8° | 15° | 3/6/84 + 3/7/66 | LI25M43LG3 | F03FS02657 |
| IMPACT 105 C/D, PLUS 105 C/D/P | Main blade | 380 | 4,4 | 3,2 | 80 | 72 | TCG | 15° | 15° | 4/9/100 + 2/9/110 + 2/14/110 | LSB38010X | F03FS07808 |
| | HW Scorer | 160 | 4,3-5,5 | 3,2 | 55 | 36 | ATB | 8° | 15° | 3/6/84 + 3/7/66 | LI25M43LG3 | F03FS02657 |
| IMPACT 90 | Main blade | 380 | 4,4 | 3,2 | 80 | 48 | TCG | 15° | 15° | 4/9/100 + 2/9/110 + 2/14/110 | LSB38009X | F03FS09164 |
| | HW Scorer | 160 | 4,3-5,5 | 3,2 | 55 | 36 | ATB | 8° | 15° | 3/6/84 + 3/7/66 | LI25M43LG3 | F03FS02657 |
| | HW Scorer | 200 | 4,3-5,5 | 3,2 | 80 | 36 | ATB | 8° | 15° | 2/14/110 | LI25M43PL3 | F03FS02683 |
| | DP Scorer | 200 | 4,3-5,1 | 3,2 | 80 | 36 | FLAT | 6° | 14° | 2/14/110 | DLI25M43PLH4 | F03FS09627 |
| | DP Scorer | 200 | 4,3-5,1 | 3,2 | 80 | 36 | FLAT | 6° | 14° | 2/14/110 | DLI25M43PLH6 | F03FS09628 |
| | Postf. scorer | 300 | 4,7 | 3,2 | 80 | 72 | ATB | 15° | 15° | 2/14/110 | LI27M DC3 | F03FS02741 |
| IMPACT 110 | Main blade | 400 | 4,4 | 3,2 | 80 | 72 | TCG | 15° | 15° | 4/9/100 + 2/9/110 + 2/14/110 + 2/14/125 | LSB40012X | F03FS09173 |
| | HW Scorer | 160 | 4,3-5,5 | 3,2 | 55 | 36 | ATB | 8° | 15° | 3/6/84 + 3/7/66 | LI25M43LG3 | F03FS02657 |
| | HW Scorer | 200 | 4,3-5,5 | 3,2 | 80 | 36 | ATB | 8° | 15° | 2/14/110 | LI25M43PL3 | F03FS02683 |
| | DP Scorer | 200 | 4,3-5,1 | 3,2 | 80 | 36 | FLAT | 6° | 14° | 2/14/110 | DLI25M43PLH4 | F03FS09627 |
| | DP Scorer | 200 | 4,3-5,1 | 3,2 | 80 | 36 | FLAT | 6° | 14° | 2/14/110 | DLI25M43PLH6 | F03FS09628 |
| | Postf. scorer | 300 | 4,7 | 3,2 | 80 | 72 | ATB | 15° | 15° | 2/14/110 | LI27M DC3 | F03FS02741 |

| Machine Type | Tool Type | D | B-B1 | b | d | Z | Tooth Type | α | β | Pin Holes | Freud Code | Art. No. |
|--------------------------|---------------|-----|---------|-----|----|----|------------|----------|---------|---|---------------------|------------|
| | | mm | mm | mm | mm | | | | | | | |
| SCM-GABBIANI | | | | | | | | | | | | |
| GALAXY 90 | Main blade | 300 | 4,4 | 3 | 80 | 60 | TCG | 15° | 15° | 4/9/100 + 2/14/110 | LSB30004X | F03FS09157 |
| | Main blade | 300 | 4,4 | 3 | 80 | 72 | TCG | 15° | 15° | 4/9/100 + 2/14/110 | LSB30008X | F03FS07804 |
| | HW Scorer | 200 | 4,3-5,5 | 3,2 | 80 | 36 | ATB | 8° | 15° | 2/14/110 | LI25M43PL3 | F03FS02683 |
| | DP Scorer | 200 | 4,3-5,1 | 3,2 | 80 | 36 | FLAT | 6° | 14° | 2/14/110 | DLI25M43PLH4 | F03FS09627 |
| | DP Scorer | 200 | 4,3-5,1 | 3,2 | 80 | 36 | FLAT | 6° | 14° | 2/14/110 | DLI25M43PLH6 | F03FS09628 |
| | Postf. scorer | 300 | 4,7 | 3,2 | 80 | 72 | ATB | 15° | 15° | 2/14/110 | LI27M DC3 | F03FS02741 |
| GALAXY 85 | Main blade | 350 | 4,4 | 3,2 | 80 | 72 | TCG | 15° | 15° | 4/9/100 + 2/14/110 + 2/14/110 | LSB35005X | F03FS07635 |
| | HW Scorer | 200 | 4,3-5,5 | 3,2 | 80 | 36 | ATB | 8° | 15° | 2/14/110 | LI25M43PL3 | F03FS02683 |
| | DP Scorer | 200 | 4,3-5,1 | 3,2 | 80 | 36 | FLAT | 6° | 14° | 2/14/110 | DLI25M43PLH4 | F03FS09627 |
| | DP Scorer | 200 | 4,3-5,1 | 3,2 | 80 | 36 | FLAT | 6° | 14° | 2/14/110 | DLI25M43PLH6 | F03FS09628 |
| GALAXY3 110, 110A | Main blade | 400 | 4,4 | 3,2 | 80 | 72 | TCG | 15° | 15° | 4/9/100 + 2/9/110 + 2/14/110 + 2/14/125 | LSB40012X | F03FS09173 |
| | HW Scorer | 200 | 4,3-5,5 | 3,2 | 80 | 36 | ATB | 8° | 15° | 2/14/110 | LI25M43PL3 | F03FS02683 |
| | DP Scorer | 200 | 4,3-5,1 | 3,2 | 80 | 36 | FLAT | 6° | 14° | 2/14/110 | DLI25M43PLH4 | F03FS09627 |
| | DP Scorer | 200 | 4,3-5,1 | 3,2 | 80 | 36 | FLAT | 6° | 14° | 2/14/110 | DLI25M43PLH6 | F03FS09628 |
| | Postf. scorer | 300 | 4,7 | 3,2 | 80 | 72 | ATB | 15° | 15° | 2/14/110 | LI27M DC3 | F03FS02741 |
| GALAXY 115 | Main blade | 400 | 4,4 | 3,2 | 80 | 72 | TCG | 15° | 15° | 4/9/100 + 2/9/110 + 2/14/110 + 2/14/125 | LSB40012X | F03FS09173 |
| | HW Scorer | 200 | 4,3-5,5 | 3,2 | 80 | 36 | ATB | 8° | 15° | 2/14/110 | LI25M43PL3 | F03FS02683 |
| | DP Scorer | 200 | 4,3-5,1 | 3,2 | 80 | 36 | FLAT | 6° | 14° | 2/14/110 | DLI25M43PLH4 | F03FS09627 |
| | DP Scorer | 200 | 4,3-5,1 | 3,2 | 80 | 36 | FLAT | 6° | 14° | 2/14/110 | DLI25M43PLH6 | F03FS09628 |
| GALAXY3 130, 130A | Main blade | 430 | 4,4 | 3,2 | 80 | 72 | TCG | 15° | 15° | 2/9/130 + 2/14/110 + 4/19/120 | LSB43009X | F03FS07909 |
| | HW Scorer | 200 | 4,3-5,5 | 3,2 | 80 | 36 | ATB | 8° | 15° | 2/14/110 | LI25M43PL3 | F03FS02683 |
| | DP Scorer | 200 | 4,3-5,1 | 3,2 | 80 | 36 | FLAT | 6° | 14° | 2/14/110 | DLI25M43PLH4 | F03FS09627 |
| | DP Scorer | 200 | 4,3-5,1 | 3,2 | 80 | 36 | FLAT | 6° | 14° | 2/14/110 | DLI25M43PLH6 | F03FS09628 |
| | Postf. scorer | 300 | 4,7 | 3,2 | 80 | 72 | ATB | 15° | 15° | 2/14/110 | LI27M DC3 | F03FS02741 |
| GALAXY3 145 | Main blade | 450 | 4,4 | 3,2 | 80 | 72 | TCG | 15° | 15° | 2/9/130 + 2/14/110 + 4/19/120 | LSB45009X | F03FS07811 |
| | HW Scorer | 200 | 4,3-5,5 | 3,2 | 80 | 36 | ATB | 8° | 15° | 2/14/110 | LI25M43PL3 | F03FS02683 |
| | DP Scorer | 200 | 4,3-5,1 | 3,2 | 80 | 36 | FLAT | 6° | 14° | 2/14/110 | DLI25M43PLH4 | F03FS09627 |
| | DP Scorer | 200 | 4,3-5,1 | 3,2 | 80 | 36 | FLAT | 6° | 14° | 2/14/110 | DLI25M43PLH6 | F03FS09628 |











| Machine Type | Tool Type | D | B-B1 | b | d | Z | Tooth Type | α | β | Pin Holes | Freud Code | Art. No. |
|------------------------|------------|-----|---------|-----|----|----|------------|----------|---------|---|--------------|------------|
| | | mm | mm | mm | mm | | | | | | | |
| GALAXY 140, ELITE | Main blade | 450 | 4,4 | 3,2 | 80 | 72 | TCG | 15° | 15° | 2/9/130 + 2/14/110 + 4/19/120 | LSB45009X | F03FS07811 |
| | HW Scorer | 200 | 4,3-5,5 | 3,2 | 80 | 36 | ATB | 8° | 15° | 2/14/110 | LI25M43PL3 | F03FS02683 |
| | DP Scorer | 200 | 4,3-5,1 | 3,2 | 80 | 36 | FLAT | 6° | 14° | 2/14/110 | DLI25M43PLH4 | F03FS09627 |
| | DP Scorer | 200 | 4,3-5,1 | 3,2 | 80 | 36 | FLAT | 6° | 14° | 2/14/110 | DLI25M43PLH6 | F03FS09628 |
| GALAXY3 | Main blade | 460 | 4,4 | 3,2 | 80 | 72 | TCG | 15° | 15° | 2/14/110 + 4/9/100 | LSB46003X | F03FS09950 |
| | HW Scorer | 200 | 4,3-5,5 | 3,2 | 80 | 36 | ATB | 8° | 15° | 2/14/110 | LI25M43PL3 | F03FS02683 |
| | DP Scorer | 200 | 4,3-5,1 | 3,2 | 80 | 36 | FLAT | 6° | 14° | 2/14/110 | DLI25M43PLH4 | F03FS09627 |
| | DP Scorer | 200 | 4,3-5,1 | 3,2 | 80 | 36 | FLAT | 6° | 14° | 2/14/110 | DLI25M43PLH6 | F03FS09628 |
| TÖRK MAKİNE | | | | | | | | | | | | |
| MP70R | Main blade | 320 | 4,4 | 3,2 | 75 | 72 | TCG | 15° | 15° | 3/7/100 + 3/13/95 | LSB32002X | F03FS09162 |
| | HW Scorer | 160 | 4,3-5,5 | 3,2 | 55 | 36 | ATB | 8° | 15° | 3/6/84 + 3/7/66 | LI25M43LG3 | F03FS02657 |
| TURANLAR | | | | | | | | | | | | |
| T-PE 433 | Main blade | 300 | 4,4 | 3 | 30 | 60 | TCG | 15° | 15° | 2/10/60 | LSB30001X | F03FS07802 |
| | Main blade | 300 | 4,4 | 3 | 30 | 72 | TCG | 15° | 15° | 2/10/60 | LSB30005X | F03FS07803 |
| | HW Scorer | 150 | 4,3-5,6 | 3,2 | 30 | 36 | ATB | 8° | 15° | - | LI25M43KC3 | F03FS02649 |
| T-PE 434 (before 2020) | Main blade | 400 | 4,4 | 3,2 | 80 | 72 | TCG | 15° | 15° | 4/9/100 + 2/9/110 + 2/14/110 + 2/14/125 | LSB40012X | F03FS07810 |
| | HW Scorer | 200 | 4,3-5,5 | 3,2 | 65 | 36 | ATB | 8° | 15° | 2/9/100 + 2/9/110 | LI25M43PI3 | F03FS02681 |
| T-PE 434 | Main blade | 430 | 4,4 | 3,2 | 80 | 72 | TCG | 15° | 15° | 2/9/130 + 2/14/110 + 4/19/120 | LSB43009X | F03FS07909 |
| | HW Scorer | 200 | 4,3-5,5 | 3,2 | 65 | 36 | ATB | 8° | 15° | 2/9/100 + 2/9/110 | LI25M43PI3 | F03FS02681 |
| T-PE 435 | Main blade | 430 | 4,4 | 3,2 | 80 | 72 | TCG | 15° | 15° | 2/9/130 + 2/14/110 + 4/19/120 | LSB43009X | F03FS07909 |
| | HW Scorer | 200 | 4,3-5,5 | 3,2 | 65 | 36 | ATB | 8° | 15° | 2/9/100 + 2/9/110 | LI25M43PI3 | F03FS02681 |
| T-PE 436 (before 2020) | Main blade | 450 | 4,8 | 3,5 | 80 | 72 | TCG | 15° | 15° | 2/14/125 + 2/9/130 + 4/19/120 | LSB45018X | F03FS07812 |
| | HW Scorer | 200 | 4,7-5,9 | 3,5 | 65 | 36 | ATB | 8° | 15° | 2/9/100 + 2/9/110 | LI25M47PI3 | F03FS02720 |































FIND THE PERFECT PANEL SIZING BLADE BY DIAMETER

































LSB X full range

































| D | B | b | d | Z | α | β | Pin Holes | Machine | Freud Code | Art. No. |
|-----|-----|-----|----|----|----------|---------|--------------------|-------------------------|---|------------|
| mm | mm | mm | mm | | | | | | | |
| 250 | 4,2 | 3 | 30 | 60 | 15° | 15° | | SCM - Techmatic, Verry |  LSB25003X | F03FS10212 |
| 250 | 4,2 | 3 | 50 | 60 | 15° | 15° | | Usikraft |  LSB25005X | F03FS10214 |
| 250 | 4,2 | 3 | 55 | 60 | 15° | 15° | | Baldan, SCM - Techmatic |  LSB25002X | F03FS10211 |
| 250 | 4,4 | 3 | 30 | 80 | 15° | 15° | 2/9/46,4 + 2/10/60 | |  LSB25004X | F03FS10213 |
| 270 | 4,2 | 3 | 55 | 60 | 15° | 15° | | SCM - Techmatic |  LSB27001X | F03FS10215 |
| 280 | 4,4 | 3,2 | 55 | 60 | 15° | 15° | 2/10/70 | Baldan |  LSB28001X | F03FS10216 |
| 290 | 4,2 | 3 | 55 | 60 | 15° | 15° | | SCM - Techmatic |  LSB29001X | F03FS10217 |
| 300 | 4,4 | 3 | 30 | 60 | 15° | 15° | 2/10/60 | Panhans |  LSB30001X | F03FS07802 |
| 300 | 4,4 | 3 | 65 | 60 | 15° | 15° | 2/9/110 | Selco |  LSB30002X | F03FS09159 |
| 300 | 4,4 | 3 | 75 | 60 | 15° | 15° | | Homag |  LSB30003X | F03FS10218 |
| 300 | 4,4 | 3 | 80 | 60 | 15° | 15° | 4/9/100 + 2/14/110 | SCM |  LSB30004X | F03FS09157 |

| D | B | b | d | Z | α | β | Pin Holes | Machine | Freud Code | Art. No. |
|----------|----------|----------|----------|----------|----------|---------|------------------------------|-----------------------|--|-----------------|
| mm | mm | mm | mm | | | | | | | |
| 300 | 4,4 | 3 | 30 | 72 | 15° | 15° | 2/10/60 | Panhans, Verry |  LSB30005X | F03FS07803 |
| 300 | 4,4 | 3,2 | 60 | 72 | 15° | 15° | 2/14/100 | Holzma |  LSB30012X | F03FS09207 |
| 300 | 4,4 | 3 | 65 | 72 | 15° | 15° | 2/9/95 + 2/9/110 | Selco |  LSB30006X | F03FS09158 |
| 300 | 4,4 | 3 | 75 | 72 | 15 | 15° | | Holzma |  LSB30007X | F03FS10219 |
| 300 | 4,4 | 3 | 80 | 72 | 15° | 15° | 4/9/100 + 2/14/110 | SCM |  LSB30008X | F03FS07804 |
| 300 | 4,4 | 3 | 75 | 96 | 15° | 15° | | |  LSB30010X | F03FS10220 |
| 305 | 4,4 | 3 | 30 | 60 | 15 | 15° | 2/10/60 | Mayer, Panhans, SCM |  LSB30501X | F03FS10221 |
| 310 | 4,4 | 3,2 | 60 | 72 | 15° | 15° | 2/14/100 | Holzma |  LSB31001X | F03FS09949 |
| 320 | 4,4 | 3,2 | 30 | 60 | 15° | 15° | | |  LSB32005X | F03FS09160 |
| 320 | 4,4 | 3,2 | 50 | 60 | 15 | 15° | 3/15/80 + 3/13/95 | Giben |  LSB32004X | F03FS10222 |
| 320 | 4,4 | 3,2 | 65 | 60 | 15° | 15° | 2/9/110 | Selco |  LSB32003X | F03FS09161 |
| 320 | 4,4 | 3,2 | 80 | 60 | 10° | 15° | 4/9/100 + 2/9/110 + 2/14/110 | |  LSB32006X | F03FS10101 |
| 320 | 4,4 | 3,2 | 60 | 72 | 15 | 15 | 2/14/100 | |  LSB32008X | F03FS10268 |
| 320 | 4,4 | 3,2 | 65 | 72 | 15° | 15° | 2/9/110 | Selco |  LSB32001X | F03FS07805 |
| 320 | 4,4 | 3,2 | 75 | 72 | 15° | 15° | 3/13/95 + 3/7/100 | Giben |  LSB32002X | F03FS09162 |
| 320 | 4,4 | 3,2 | 80 | 72 | 15° | 15° | 4/9/100 + 2/9/110 + 2/14/110 | |  LSB32007X | F03FS10267 |
| 350 | 4,2 | 3,2 | 80 | 96 | 15° | 15° | | |  LSB35011X | F03FS10225 |
| 350 | 4,4 | 3,2 | 30 | 54 | 15° | 15° | 2/10/60 | Panhans, Scheer |  LSB35001X | F03FS10223 |
| 350 | 4,4 | 3,2 | 60 | 54 | 15° | 15° | 2/14/100 | Holzma |  LSB35002X | F03FS10224 |
| 350 | 4,4 | 3,2 | 30 | 72 | 15° | 15° | 2/10/60 | Panhans, Scheer |  LSB35003X | F03FS07630 |
| 350 | 4,4 | 3,2 | 50 | 72 | 15° | 15° | 4/13/80 | Giben |  LSB35006X | F03FS07709 |
| 350 | 4,4 | 3,2 | 60 | 72 | 15° | 15° | 2/14/100 | Holzma |  LSB35004X | F03FS07636 |
| 350 | 4,4 | 3,2 | 65 | 72 | 15° | 15° | 2/9/110 | Selco |  LSB35013X | F03FS09659 |
| 350 | 4,4 | 3,2 | 75 | 72 | 15° | 15° | | Giben, Hansol Machine |  LSB35008X | F03FS07634 |
| 350 | 4,4 | 3,2 | 80 | 72 | 15° | 15° | 4/9/100 + 2/9/110 + 2/14/110 | Gabbiani |  LSB35005X | F03FS07635 |
| 355 | 4,4 | 3,2 | 75 | 54 | 15° | 15° | | Giben |  LSB35502X | F03FS10226 |
| 355 | 4,4 | 3,2 | 80 | 54 | 15° | 15° | 4/9/100 + 2/9/110 + 2/14/110 | Gabbiani |  LSB35503X | F03FS09205 |
| 355 | 4,4 | 3,2 | 30 | 72 | 15° | 15° | 2/10/60 | Panhans, SCM |  LSB35504X | F03FS07674 |
| 355 | 4,4 | 3,2 | 65 | 72 | 15° | 15° | 2/9/95 + 2/9/110 | Selco |  LSB35508X | F03FS08740 |
| 355 | 4,4 | 3,2 | 75 | 72 | 15° | 15° | 4/15/105 + 2/7/110 | Giben, KDT, Hold |  LSB35505X | F03FS07633 |

| D | B | b | d | Z | α | β | Pin Holes | Machine | Freud Code | Art. No. |
|-----------|-----------|-----------|-----------|----------|----------|---------|------------------------------|------------------|--|-----------------|
| mm | mm | mm | mm | | | | | | | |
| 355 | 4,4 | 3,2 | 75 | 72 | 15° | 15° | 3/7/100 | Gabbiani |  LSB35507X | F03FS07710 |
| 355 | 4,4 | 3,2 | 80 | 72 | 15° | 15° | 4/9/100 + 2/9/110 + 2/14/110 | Gabbiani |  LSB35506X | F03FS09163 |
| 360 | 4,4 | 3 | 65 | 60 | 15° | 15° | 2/9/110 | Selco |  LSB36001X | F03FS10227 |
| 360 | 4,4 | 3,2 | 30 | 72 | 15° | 15° | 2/13/94 | Schelling |  LSB36003X | F03FS09341 |
| 360 | 4,4 | 3,2 | 65 | 72 | 15° | 15° | 2/9/110 | Selco |  LSB36002X | F03FS07673 |
| 370 | 4,4 | 3,2 | 30 | 72 | 15° | 15° | 2/10/60 | Schelling |  LSB37001X | F03FS10228 |
| 380 | 4,4 | 3,2 | 80 | 48 | 15° | 15° | 4/9/100 + 2/9/110 + 2/14/110 | Gabbiani |  LSB38009X | F03FS09164 |
| 380 | 4,4 | 3,2 | 50 | 60 | 15° | 15° | 4/13/80 | Giben |  LSB38007X | F03FS10230 |
| 380 | 4,4 | 3,2 | 60 | 60 | 15° | 15° | 2/14/100 | Holzma |  LSB38001X | F03FS07806 |
| 380 | 4,4 | 3,2 | 30 | 72 | 15° | 15° | 2/08/83 | |  LSB38011X | F03FS10231 |
| 380 | 4,4 | 3,2 | 50 | 72 | 15° | 15° | 4/13/80 | Giben |  LSB38008X | F03FS09165 |
| 380 | 4,4 | 3,2 | 60 | 72 | 15° | 15° | 2/14/100 | Holzma |  LSB38002X | F03FS07631 |
| 380 | 4,4 | 3,2 | 65 | 72 | 15° | 15° | 2/9/110 | Selco |  LSB38014X | F03FS09166 |
| 380 | 4,4 | 3,2 | 75 | 72 | 15° | 15° | 2/14/100 | Holzma, Wonpoong |  LSB38012X | F03FS07672 |
| 380 | 4,4 | 3,2 | 80 | 72 | 15° | 15° | 4/9/100 + 2/9/110 + 2/14/110 | Gabbiani |  LSB38010X | F03FS07808 |
| 380 | 4,4 | 3,2 | 60 | 84 | 15° | 15° | 2/14/100 | Holzma |  LSB38015X | F03FS08989 |
| 380 | 4,4 | 3,2 | 80 | 96 | 15° | 15° | 4/9/100 + 2/9/110 + 2/14/110 | Gabbiani |  LSB38013X | F03FS07809 |
| 380 | 4,8 | 3,5 | 60 | 60 | 15° | 15° | 2/14/100 | Holzma |  LSB38003X | F03FS10229 |
| 380 | 4,8 | 3,5 | 60 | 72 | 15° | 15° | 2/14/100 | Holzma |  LSB38004X | F03FS07632 |
| 380 | 4,8 | 3,5 | 60 | 84 | 15° | 15° | 2/14/100 | Holzma |  LSB38005X | F03FS07807 |
| 390 | 4,4 | 3,2 | 80 | 72 | 15° | 15° | 2/14/110 | Sigma |  LSB39001X | F03FS09167 |
| 400 | 4,4 | 3,2 | 30 | 48 | 15° | 15° | | |  LSB40001X | F03FS09168 |
| 400 | 4,4 | 3,2 | 80 | 48 | 15° | 15° | 2/9/110 + 4/9/100 + 2/14/110 | Gabbiani |  LSB40010X | F03FS10233 |
| 400 | 4,4 | 3,2 | 30 | 60 | 15° | 15° | 2/10/60 | |  LSB40004X | F03FS09169 |
| 400 | 4,4 | 3,2 | 75 | 60 | 15° | 15° | 4/15/105 | Giben |  LSB40005X | F03FS09170 |
| 400 | 4,4 | 3,2 | 80 | 60 | 15° | 15° | 2/9/130 + 4/19/120 | Selco |  LSB40006X | F03FS10232 |
| 400 | 4,4 | 3,2 | 80 | 60 | 15° | 15° | 4/9/100 + 2/9/110 + 2/14/110 | Gabbiani |  LSB40011X | F03FS09171 |
| 400 | 4,4 | 3,2 | 30 | 72 | 15° | 15° | 2/10/60 + 2/13/94 | Scheer |  LSB40007X | F03FS07725 |
| 400 | 4,4 | 3,2 | 50,8 | 72 | 15° | 15° | 2/16/127 + 4/13/80 | |  LSB40018X | F03FS08957 |
| 400 | 4,4 | 3,2 | 60 | 72 | 15° | 15° | 2/11/85 + 2/14/100 | Antho |  LSB40017X | F03FS09272 |

| D | B | b | d | Z | α | β | Pin Holes | Machine | Freud Code | Art. No. |
|-----|-----|-----|----|----|----------|---------|-------------------------------|---|--|------------|
| mm | mm | mm | mm | | | | | | | |
| 400 | 4,4 | 3,2 | 65 | 72 | 15° | 15° | 2/9/110 | Selco |  LSB40016X | F03FS09172 |
| 400 | 4,4 | 3,2 | 75 | 72 | 15° | 15° | 4/15/105 + 2/7/110 + 2/14/100 | Giben, Haisung Woodworking Machinery, Hansol Machine, HOMAG, Hyundai Sangi, KDT |  LSB40008X | F03FS07726 |
| 400 | 4,4 | 3,2 | 80 | 72 | 15° | 15° | 2/15/105 + 2/9/130 + 4/19/120 | Selco, MAS |  LSB40009X | F03FS07810 |
| 400 | 4,4 | 3,2 | 80 | 72 | 15° | 15° | 4/9/100 + 2/9/110 + 2/14/110 | Gabbiani |  LSB40012X | F03FS09173 |
| 400 | 4,4 | 3,2 | 60 | 84 | 15° | 15° | 2/14/100 | Nanxing |  LSB40021X | F03FS09255 |
| 400 | 4,4 | 3,2 | 75 | 84 | 15° | 15° | 4/15/105 + 2/7/110 | KDT |  LSB40019X | F03FS08990 |
| 400 | 4,8 | 3,5 | 60 | 72 | 15° | 15° | 2/14/125 | Holzma |  LSB40013X | F03FS07711 |
| 420 | 4,4 | 3,2 | 80 | 60 | 15° | 15° | 4/9/100 + 2/9/110 + 2/14/110 | Gabbiani |  LSB42004X | F03FS10235 |
| 420 | 4,4 | 3,2 | 50 | 72 | 15° | 15° | 2/9/130 + 4/19/120 | Selco |  LSB42006X | F03FS09174 |
| 420 | 4,4 | 3,2 | 80 | 72 | 15° | 15° | 4/9/100 + 2/9/110 + 2/14/110 | Gabbiani |  LSB42005X | F03FS09175 |
| 420 | 4,8 | 3,5 | 60 | 60 | 15° | 15° | 2/14/125 | Holzma |  LSB42001X | F03FS10234 |
| 420 | 4,8 | 3,5 | 60 | 84 | 15° | 15° | 2/14/100 + 2/14/125 | Holzma |  LSB42002X | F03FS09176 |
| 430 | 4,4 | 3,2 | 30 | 48 | 15° | 15° | | |  LSB43001X | F03FS10236 |
| 430 | 4,4 | 3,2 | 75 | 48 | 15° | 15° | 4/15/105 | Giben |  LSB43002X | F03FS10237 |
| 430 | 4,4 | 3,2 | 30 | 60 | 15° | 15° | 2/10/60 | |  LSB43004X | F03FS10238 |
| 430 | 4,4 | 3,2 | 75 | 60 | 15° | 15° | 4/15/105 | Giben |  LSB43005X | F03FS10239 |
| 430 | 4,4 | 3,2 | 80 | 60 | 15° | 15° | 2/9/130 + 2/14/110 + 4/19/120 | Selco - Gabbiani |  LSB43006X | F03FS10240 |
| 430 | 4,4 | 3,2 | 30 | 72 | 15° | 15° | | |  LSB43007X | F03FS09177 |
| 430 | 4,4 | 3,2 | 65 | 72 | 15° | 15° | 2/9/110 | Selco |  LSB43012X | F03FS09178 |
| 430 | 4,4 | 3,2 | 75 | 72 | 15° | 15° | 4/15/105 + 2/7/110 | Giben |  LSB43008X | F03FS07908 |
| 430 | 4,4 | 3,2 | 80 | 72 | 15° | 15° | 2/9/130 + 2/14/110 + 4/19/120 | Selco, Gabbiani |  LSB43009X | F03FS07909 |
| 430 | 4,4 | 3,2 | 75 | 96 | 15° | 15° | 4/15/105 + 2/7/110 | Giben Prismatic |  LSB43010X | F03FS09179 |
| 430 | 4,8 | 3,5 | 70 | 72 | 15° | 15° | 4/11/130 | Selco |  LSB43013X | F03FS09180 |
| 450 | 4,4 | 3,2 | 30 | 48 | 15° | 15° | 2/09/60 | Mayer, Panhans, SCM |  LSB45001X | F03FS10241 |
| 450 | 4,4 | 3,2 | 60 | 48 | 15° | 15° | 2/14/125 | Holzma |  LSB45002X | F03FS10242 |
| 450 | 4,4 | 3,2 | 30 | 60 | 15° | 15° | 2/10/60 | Mayer, Panhans, SCM |  LSB45004X | F03FS10243 |
| 450 | 4,4 | 3,2 | 60 | 60 | 15° | 15° | 2/14/125 | Holzma |  LSB45005X | F03FS10244 |
| 450 | 4,4 | 3,2 | 80 | 60 | 10° | 15° | 2/9/130 + 4/19/120 + 2/14/110 | Selco - Gabbiani |  LSB45006X | F03FS10245 |
| 450 | 4,4 | 3,2 | 30 | 72 | 15° | 15° | 2/10/60 + 2/14/95 | Mayer, Panhans, SCM |  LSB45007X | F03FS09181 |
| 450 | 4,4 | 3,2 | 60 | 72 | 15° | 15° | 2/14/125 | Holzma |  LSB45008X | F03FS09182 |

| D | B | b | d | Z | α | β | Pin Holes | Machine | Freud Code | Art. No. | |
|-----|-----|-----|----|----|----------|---------|-------------------------------|----------------------|---|-----------|------------|
| mm | mm | mm | mm | | | | | | | | |
| 450 | 4,4 | 3,2 | 80 | 72 | 15° | 15° | 2/9/130 + 2/14/110 + 4/19/120 | Selco, Gabbiani |  | LSB45009X | F03FS07811 |
| 450 | 4,8 | 3,5 | 30 | 72 | 10° | 15° | 2/09/60 | Scheer |  | LSB45016X | F03FS10246 |
| 450 | 4,8 | 3,5 | 60 | 72 | 15° | 15° | 2/14/125 + 2/17/100 | Holzma, Nanxing |  | LSB45017X | F03FS07391 |
| 450 | 4,8 | 3,5 | 80 | 72 | 15° | 15° | 2/9/130 + 4/19/120 | Selco |  | LSB45018X | F03FS07812 |
| 450 | 4,8 | 3,5 | 60 | 84 | 10° | 15° | 2/14/125 | Holzma |  | LSB45019X | F03FS10247 |
| 460 | 4,4 | 3,2 | 30 | 72 | 15° | 15° | 2/13/94 | Schelling |  | LSB46001X | F03FS08922 |
| 460 | 4,4 | 3,2 | 75 | 72 | 15° | 15° | 2/7/110 | Giben |  | LSB46002X | F03FS07914 |
| 460 | 4,4 | 3,2 | 80 | 72 | 15° | 15° | 2/14/110 + 4/9/100 | Gabbiani |  | LSB46003X | F03FS09950 |
| 470 | 4,4 | 3,2 | 75 | 48 | 15° | 15° | 4/15/105 | Giben |  | LSB47001X | F03FS10248 |
| 470 | 4,4 | 3,2 | 75 | 60 | 15° | 15° | 4/15/105 | Giben |  | LSB47002X | F03FS10249 |
| 470 | 4,4 | 3,2 | 75 | 72 | 15° | 15° | 4/15/105 | Giben, Hyundai Sangi |  | LSB47003X | F03FS09183 |
| 470 | 4,4 | 3,2 | 75 | 96 | 15° | 15° | 4/15/105 | Giben |  | LSB47004X | F03FS09184 |
| 470 | 4,8 | 3,5 | 70 | 72 | 15° | 15° | 4/11/130 | Selco |  | LSB47005X | F03FS09185 |
| 480 | 4,4 | 3,2 | 30 | 72 | 15° | 15° | 2/10/60 + 2/13/94 | Schelling |  | LSB48007X | F03FS09914 |
| 480 | 4,8 | 3,5 | 80 | 60 | 15° | 15° | 2/9/130 + 4/19/120 | Selco |  | LSB48003X | F03FS09186 |
| 480 | 4,8 | 3,5 | 30 | 72 | 15° | 15° | 2/10/60 + 2/13/94 | Schelling |  | LSB48004X | F03FS09187 |
| 480 | 4,8 | 3,5 | 60 | 72 | 15° | 15° | 2/19/120 | |  | LSB48006X | F03FS10269 |
| 480 | 4,8 | 3,5 | 80 | 72 | 15° | 15° | 2/9/130 + 4/19/120 | Selco |  | LSB48001X | F03FS09188 |
| 500 | 4,4 | 3,2 | 30 | 60 | 15° | 15° | | Schelling |  | LSB50003X | F03FS10250 |
| 500 | 4,4 | 3,2 | 30 | 72 | 15° | 15° | | Schelling |  | LSB50005X | F03FS10251 |
| 500 | 4,8 | 3,5 | 60 | 60 | 15° | 15° | 2/11/115 | Holzma |  | LSB50009X | F03FS09189 |
| 500 | 4,8 | 3,5 | 75 | 60 | 15° | 15° | 4/15/105 | Giben |  | LSB50010X | F03FS09190 |
| 500 | 4,8 | 3,5 | 60 | 72 | 15° | 15° | 2/11/115 | Holzma |  | LSB50011X | F03FS09191 |
| 510 | 4,8 | 3,5 | 80 | 72 | 15° | 15° | 2/9/130 + 4/19/120 | Selco |  | LSB51001X | F03FS09984 |
| 520 | 4,4 | 3,2 | 30 | 54 | 15° | 15° | 2/13/94 | Schelling |  | LSB52005X | F03FS10253 |
| 520 | 4,4 | 3,2 | 30 | 72 | 15° | 15° | 2/13/94 | Schelling |  | LSB52008X | F03FS09602 |
| 520 | 4,8 | 3,5 | 60 | 60 | 15° | 15° | 2/11/115 + 2/19/120 | Holzma |  | LSB52002X | F03FS10252 |
| 520 | 4,8 | 3,5 | 70 | 60 | 15° | 15° | 4/11/130 | |  | LSB52009X | F03FS09958 |
| 520 | 4,8 | 3,5 | 30 | 72 | 15° | 15° | 2/13/94 | Schelling |  | LSB52007X | F03FS09319 |
| 520 | 4,8 | 3,5 | 60 | 72 | 15° | 15° | 2/11/115 + 2/19/120 | Holzma |  | LSB52003X | F03FS09192 |

| D | B | b | d | Z | α | β | Pin Holes | Machine |  | Freud Code | Art. No. |
|-----------|-----------|-----------|-----------|-----------|-----------|-----------|--------------------------------|----------------|---|-------------------|-----------------|
| mm | mm | mm | mm | mm | mm | mm | mm | mm | mm | mm | mm |
| 520 | 4,8 | 3,5 | 70 | 72 | 15° | 15° | 4/11/130 | Selco |  | LSB52006X | F03FS09193 |
| 530 | 4,8 | 3,5 | 75 | 72 | 15° | 15° | 2/7/110 | Giben |  | LSB53004X | F03FS09651 |
| 530 | 5,2 | 3,5 | 30 | 60 | 15° | 15° | | Schelling |  | LSB53001X | F03FS09194 |
| 530 | 5,2 | 3,5 | 100 | 60 | 15° | 15° | 2/7/140 | |  | LSB53003X | F03FS09195 |
| 530 | 5,8 | 4 | 60 | 60 | 15° | 15° | 1/11/85 | Anthon |  | LSB53002X | F03FS10254 |
| 540 | 4,8 | 3,5 | 60 | 60 | 15° | 15° | 2/11/115 + 2/19/120 | Holzma Typ 33 |  | LSB54002X | F03FS10255 |
| 540 | 4,8 | 3,5 | 60 | 72 | 15° | 15° | 2/11/115 + 2/19/120 | Holzma Typ 33 |  | LSB54003X | F03FS10256 |
| 550 | 5 | 3,5 | 40 | 72 | 15° | 15° | 2/13/122 | Schelling |  | LSB55007X | F03FS09216 |
| 550 | 5,2 | 3,5 | 80 | 48 | 15° | 15° | 2/14/110 | Gabbiani |  | LSB55005X | F03FS10257 |
| 550 | 5,2 | 3,5 | 40 | 60 | 15° | 15° | 2/13/122 | |  | LSB55009X | F03FS09915 |
| 550 | 5,2 | 3,5 | 60 | 60 | 15° | 15° | | |  | LSB55002X | F03FS09196 |
| 550 | 5,2 | 3,5 | 75 | 60 | 15° | 15° | 4/10,5/140 | |  | LSB55010X | F03FS10030 |
| 550 | 5,2 | 3,5 | 80 | 60 | 15° | 15° | 2/14/110 | Gabbiani |  | LSB55006X | F03FS09197 |
| 550 | 5,2 | 3,5 | 90 | 60 | 15° | 15° | 4/10,5/140 | Giben |  | LSB55008X | F03FS09970 |
| 565 | 5 | 3,5 | 100 | 72 | 15° | 15° | | Giben |  | LSB56504X | F03FS09215 |
| 565 | 5,2 | 3,5 | 100 | 60 | 15° | 15° | | Giben |  | LSB56502X | F03FS09198 |
| 570 | 4,8 | 3,5 | 60 | 60 | 15° | 15° | 2/11/115 + 2/19/120 | Holzma |  | LSB57001X | F03FS09199 |
| 600 | 5,8 | 4 | 60 | 60 | 15° | 15° | 2/11/115 + 2/19/120 | Holzma Typ 33 |  | LSB60001X | F03FS09200 |
| 600 | 5,8 | 4 | 70 | 60 | 15° | 15° | 4/11/130 | |  | LSB60004X | F03FS10258 |
| 600 | 5,8 | 4 | 75 | 60 | 15° | 15° | 4/6,5/130 + 4/11/130 | Selco |  | LSB60006X | F03FS10259 |
| 600 | 5,8 | 4 | 60 | 72 | 15° | 15° | 2/11/115 + 2/19/120 | Holzma Typ 33 |  | LSB60002X | F03FS09201 |
| 670 | 6,2 | 4,2 | 40 | 60 | 18° | 13° | 2/17/140 + 2/13/140 | Schelling |  | LSB67003X | F03FS09202 |
| 670 | 6,2 | 4,2 | 40 | 72 | 15° | 15° | 2/17/140 + 2/13/140 | Schelling |  | LSB67004X | F03FS10260 |
| 680 | 6,2 | 4,2 | 40 | 60 | 18° | 13° | 2/13/140 + 2/17/140 + 2/13/114 | Schelling |  | LSB68001X | F03FS09203 |
| 720 | 6,4 | 4,4 | 40 | 60 | 18° | 13° | 2/14/114 + 2/14/140 | Schelling |  | LSB72001X | F03FS09204 |

Precisely the best

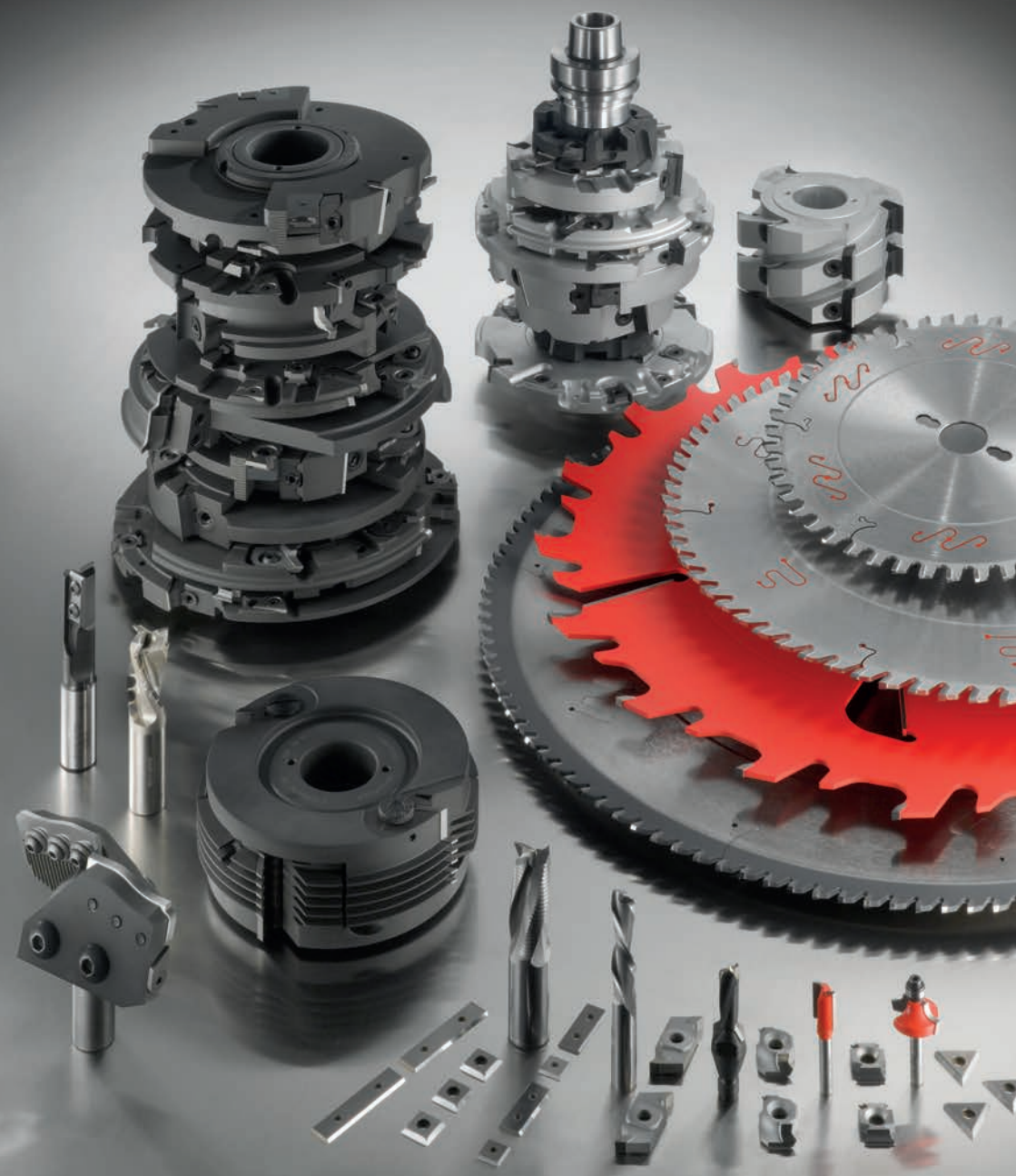



Freud - Leading the industrial market since 1962

Freud is a worldwide leader in the cutting tool industry and the biggest manufacturer of premium circular saw blades. Since 1962 Freud designs and produces an extensive range of superior quality circular saw blades, cutter heads & brazed cutters, drilling, routing & CNC tools as well as knives and accessories.

Freud technologies and solutions Perfection crafted for your needs

Freud premium quality cutting tools are produced with unique and innovative features. The company owns and controls the entire tool manufacturing process, with a full and strict monitoring over quality, across its plants in Italy. The continuous investment in Research & Development, combined with Freud strong engineering competence and advanced technologies, results in products with innovative features, extreme precision and extended lifetime. Always the right solution for your application needs.



Technological supremacy In-house Carbide production

Leader in Carbide manufacturing since 1980: Freud prides itself of a unique in-house production and sintering of Carbide components, for superior quality cutting tools. Freud TiCo, a specially formulated, highly compact combination of Titanium and Cobalt Carbide, ensures maximum precision and long lasting sharpness of the cutting edge. The ability to formulate dedicated recipes, for standard and customised applications, delivers the highest tool performance.

Global distribution Worldwide services wherever you are

Freud's belief in "think global and act local" has led the company to develop an extensive network of selected partners and subsidiaries, in over 90 countries worldwide. This to better support their customers wherever they are.



freud

freud S.p.A.
Società Unipersonale
Via Remigio Solari, 7
33050 Pavia di Udine (UD) IT

www.freudtools.com



MKFRM 219 - F03FA23637 - Printed in Italy - September 2022 - Rev. 0