

T182M

TESTE PORTACOLTELLI PER SCANALATURE DI GUIDA LATERALE GROOVE BED CUTTERHEADS WITH DISPOSABLE KNIVES

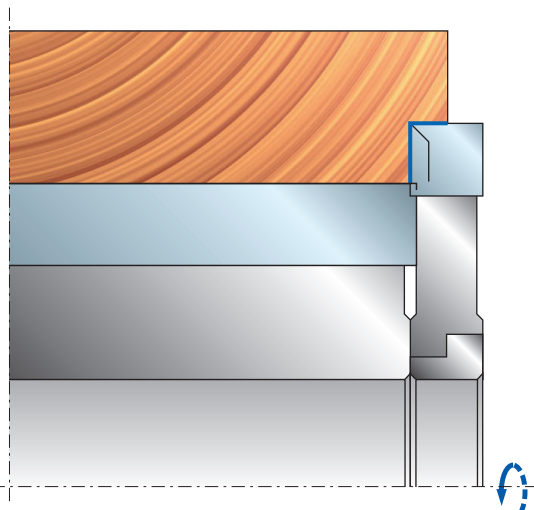
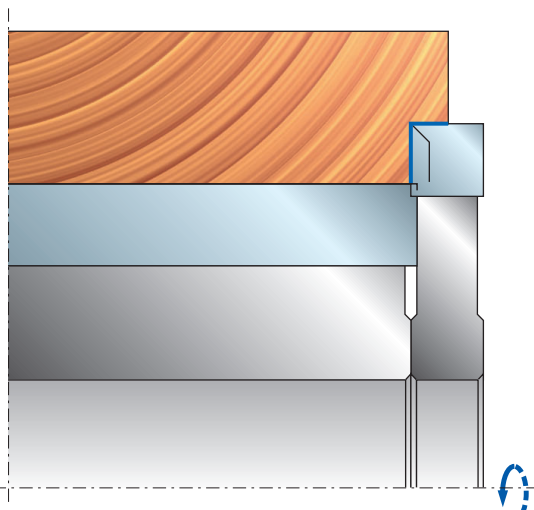
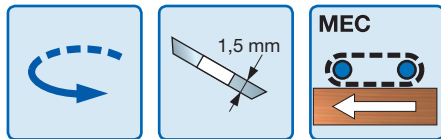

D mm	B mm	d mm	Z	R	CODICE CODE
150	10	40	4	2	T182M EB3
150	10	40	3	3	T182M DB3
145	12	40	4	2	T182M EA3
145	12	40	3	3	T182M AA3
145	10	40	3	3	T182M AB3*
120	12	35	3	3	T182M BB3
120	12	35	2	2	T182M CB3

> **Art. T182M:** Si utilizza in accoppiamento con utensili TM06M-TM07M.

> **Item T182M:** For use in combination with TM06M-TM07M to cut guiding rebates.

ARTICOLO ITEM	UTILIZZARE CON: IN CONJUNCTION WITH ITEM:
T182M AB3*	TM06M - TM07M Ø125
T182M BB3	TM07M AF3
T182M AA3	TM06M - TM07M Ø125
T182M CB3	TM06M PC3 - TM06M PH3
T182M DB3	TM06M - TM07M
T182M EA3	TM17M - TM18M - T102M
T182M EB3	TM17M - TM18M - T102M

> * Va montata su scorniciatrici Casadei e S.C.M.

> * For use on Casadei and S.C.M. moulders.







	PARTI DI RICAMBIO SPARE PARTS	DIMENSIONI DIMENSIONS	CODICE CODE
AA3	Coltello / Knife	12 x 12 x 1,5	CG01M BA3
	Cuneo / Wedge	15 x 10 x 8	CN01M BA9
	Flangia / Flange	68 x 10 x 40	FX01M HC9
AB3	Vite / Screw	M6 x 16	VT03M D19
	Coltello / Knife	9,6 x 12 x 1,5	CG01M MA3
	Cuneo / Wedge	15 x 8 x 8	CN09M DB9
BB3	Vite / Screw	M5 x 19	VT11M AA9
	Coltello / Knife	11 x 12 x 1,5	CG01M NA3
	Cuneo / Wedge	15 x 10 x 8	CN01M BA9
CB3	Vite / Screw	M6 x 16	VT03M D19
	Coltello / Knife	12 x 12 x 1,5	CG06M AA3
	Cuneo / Wedge	15 x 10 x 8	CN01M BA9
DB3	Vite / Screw	M6 x 16	VT03M D19
	Coltello / Knife	9,6 x 12 x 1,5	CG01M MA3
	Cuneo / Wedge	15 x 8 x 8	CN09M DB9
EA3	Vite / Screw	M5 x 16	VT03M BB9
	Coltello / Knife	12 x 12 x 1,5	CG01M BA3
	Cuneo / Wedge	15 x 10 x 8	CN09MS AA9
	Flangia / Flange	68 x 10 x 40	FX01M HC9
	Vite / Screw	M6 x 22	VT19M AB9
EB3	Ogiva / Nut	10 x 11,5 x 6	VT20M AA9
	Coltello / Knife	9,6 x 12 x 1,5	CG01M MA3
	Cuneo / Wedge	15 x 8 x 8	CN09M AH9
	Vite / Screw	M6 x 22	VT19M AB9
	Ogiva / Nut	9 x 10,5 x 6	VT20M GA9
	Rasante / Spur	14 x 14 x 2	RG01M AA3
	Vite / Screw	M5 x 8	VT05M AA9

T183M

TESTA PORTACOLTELLI PER SCANALATURE DI GUIDA LATERALE GROOVE BED CUTTERHEAD WITH DISPOSABLE KNIVES

D mm	B mm	d mm	Z	R	CODICE CODE
145	12	40	4	2	T183M AA3

- > **Art. T183M:** Per l'esecuzione di scanalature di guida su corniciatrice S.C.M.
- > **Item T183M:** For cutting guide grooves in solid wood for S.C.M. moulding machines.

PARTI DI RICAMBIO SPARE PARTS	DIMENSIONI DIMENSIONS	CODICE CODE
Coltello / Knife	 12 x 12 x 1,5	CG01M BA3
Cuneo / Wedge	 15 x 10 x 8	CN09MS AA9
Vite / Screw	 M6 x 22	VT19M AB9
Ogiva / Nut	 10 x 11,5 x 6	VT20M AA9
Rasante / Spur	 14 x 14 x 2	RG01M AA3
Vite / Screw	 M5 x 8	VT05M AA9
Chiave / Allen key	 3 x 110	CB03M AA9

