

DLI04D DLI04S

DESTRA
RIGHT
SINISTRA
LEFT

PCD - LAME INCISORE CON DENTE INCLINATO PCD - BEVELLED TOOTH SCORING SAWBLADES



D mm	B / b mm	d mm	Z	CODICE CODE
150	3,2 / 2,2	55	20	DLI04D6LE5
150	3,2 / 2,2	60	20	DLI04D6LF5
200	3,2 / 2,2	55	30	DLI04D6PE5
200	3,2 / 2,2	60	30	DLI04D6PF5
150	3,2 / 2,2	55	20	DLI04S6LE5
150	3,2 / 2,2	60	20	DLI04S6LF5
200	3,2 / 2,2	55	30	DLI04S6PE5
200	3,2 / 2,2	60	30	DLI04S6PF5

> **Impiego:** Per pannelli di truciolare o MDF rivestiti con laminati plastici, laccati lucidi, melaminici ed altri compositi di legno.

Macchine: Squadratrici singole, doppie e squadrabordatrici.

Caratteristiche: Dente inclinato.

Se usate in condizioni ottimali garantiscono una durata fino a 80 volte superiore all'articolo corrispondente in HW.

N.B.: Le lame possono essere costruite anche nella versione "Economica" con placchetta di altezza 4 mm. (Nell'ordine sostituire la cifra "6" del codice con il "4")

Es.: DLI04D6LE5 --> Lama Incisore
DLI04D4LE5 --> Lama Incisore "Economica"

Sinistra
Left | Destra
Right

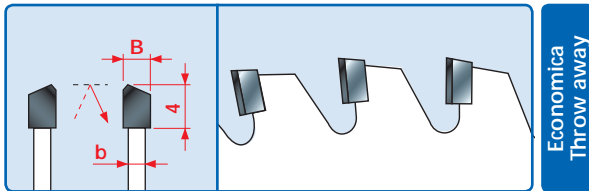

CARATTERISTICHE DEL DENTE - TOOTH'S FEATURES

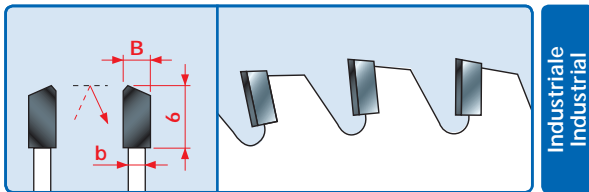

CARATTERISTICHE DEL DENTE - TOOTH'S FEATURES



> **Application:** PCD scoring sawblade for squaring machines, for cutting with excellent finishes of melamine chipboard, MDF, laminates and gloss lacquered materials.

Machines: Single-side or double-end tenoners and squaring edgbanding machines.

Features: Inclined tooth.

Up to 80 times longer life than the similar HW sawblades.

N.B. The sawblades can also be manufactured in the "Economical" version, with a plate with a height of 4 mm (to order, substitute the number "6" in the code with the number "4").

Ex.: DLI04D6LE5 --> Scoring sawblade.
DLI04D4LE5 --> "Economical" scoring sawblade

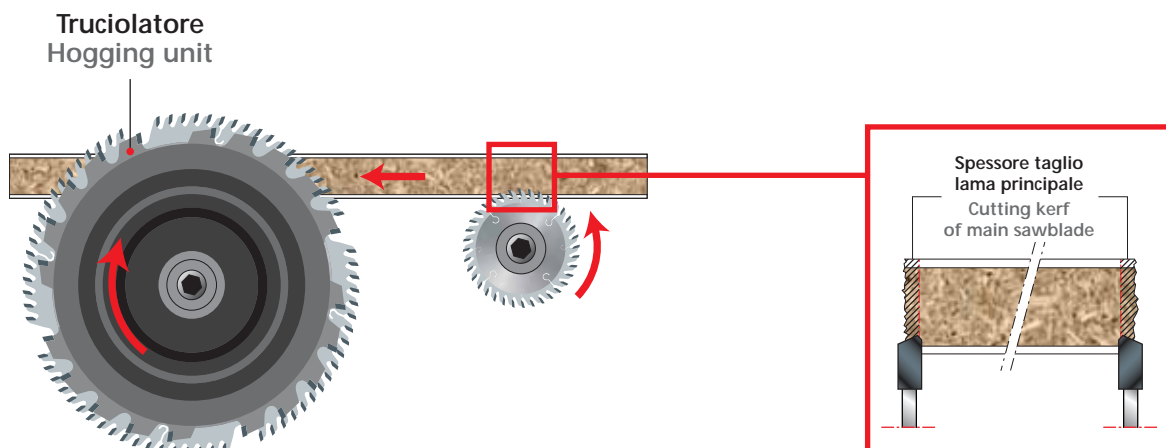

DLI14D DLI14S

DESTRA
RIGHT
SINISTRA
LEFT

PCD - LAME INCISORE CON DENTE INCLINATO PCD - BEVELLED TOOTH SCORING SAWBLADES

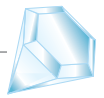

D mm	B / b mm	d mm	Z	CODICE CODE
150	3,2 / 2,2	55	24	DLI14D6LE5
150	3,2 / 2,2	60	24	DLI14D6LF5
180	3,2 / 2,2	55	30	DLI14D6OE5
180	3,2 / 2,2	60	30	DLI14D6OF5
200	3,2 / 2,2	55	36	DLI14D6PE5
200	3,2 / 2,2	60	36	DLI14D6PF5
150	3,2 / 2,2	55	24	DLI14S6LE5
150	3,2 / 2,2	60	24	DLI14S6LF5
180	3,2 / 2,2	55	30	DLI14S6OE5
180	3,2 / 2,2	60	30	DLI14S6OF5
200	3,2 / 2,2	55	36	DLI14S6PE5
200	3,2 / 2,2	60	36	DLI14S6PF5

Sinistra
Left

Destra
Right

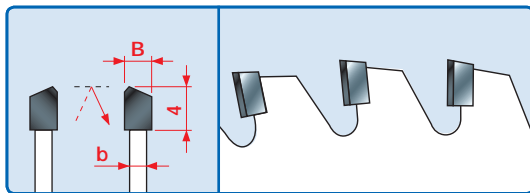

Economica
Throw away

CARATTERISTICHE DEL DENTE - TOOTH'S FEATURES

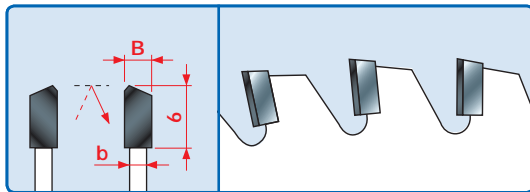

Industriale
Industrial

CARATTERISTICHE DEL DENTE - TOOTH'S FEATURES



> **Impiego:** Per pannelli di truciolare o MDF rivestiti con laminati plastici, laccati lucidi, melaminici ed altri composti di legno.

Macchine: Squadratrici singole, doppie e squadrabordatrici.

Caratteristiche: Dente inclinato.

Se usate in condizioni ottimali, garantiscono una durata fino a 80 volte superiore all'articolo corrispondente in HW.

N.B.: Le lame possono essere costruite anche nella versione "Economica" con placchetta di altezza 4 mm. (Nell'ordine sostituire la cifra "6" del codice con il "4")

Es.: DLI14D6LE5 --> Lama Incisore

DLI14D4LE5 --> Lama Incisore "Economica"

> **Application:** PCD scoring sawblade for squaring machines, for cutting with excellent finishes of melamine chipboard, MDF, laminates and gloss lacquered materials.

Machines: Single-side or double-end tenoners and squaring edgbanding machines.

Features: Inclined tooth. Up to 80 times longer life than the similar HW sawblades.

N.B. The sawblades can also be manufactured in the "Economical" version, with a plate with a height of 4 mm (to order, substitute the number "6" in the code with the number "4").

Ex.: DLI14D6LE5 --> Scoring sawblade.

DLI14D4LE5 --> "Economical" scoring sawblade.

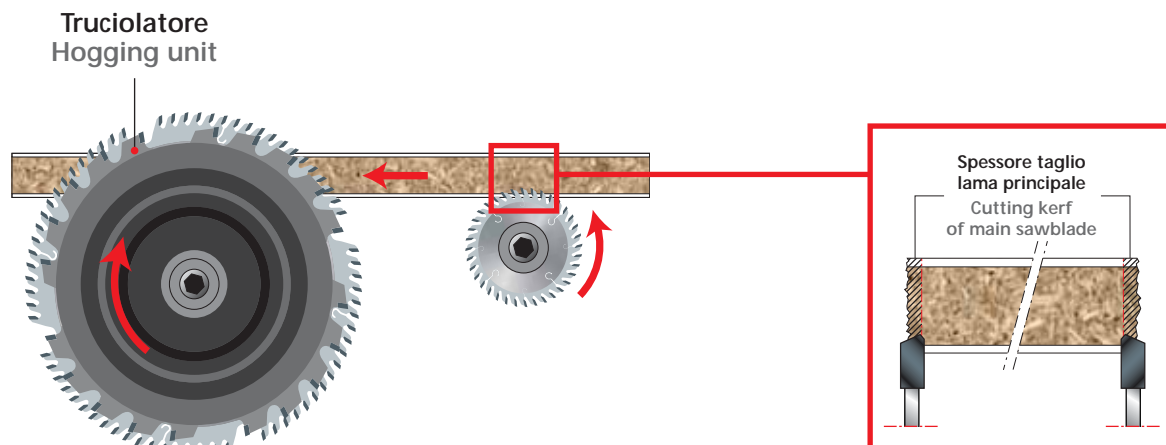

DLI24D DLI24S

DESTRA
RIGHT
SINISTRA
LEFT

PCD - LAME INCISORE CON DENTE INCLINATO PCD - BEVELLED TOOTH SCORING SAWBLADES



D mm	B / b mm	d mm	Z	CODICE CODE
150	3,2 / 2,2	55	30	DLI24D6LE5
150	3,2 / 2,2	60	30	DLI24D6LF5
200	3,2 / 2,2	55	48	DLI24D6PE5
200	3,2 / 2,2	60	48	DLI24D6PF5
150	3,2 / 2,2	55	30	DLI24S6LE5
150	3,2 / 2,2	60	30	DLI24S6LF5
200	3,2 / 2,2	55	48	DLI24S6PE5
200	3,2 / 2,2	60	48	DLI24S6PF5

> **Impiego:** Per pannelli di truciolare o MDF rivestiti con laminati plastici, laccati lucidi, melaminici ed altri compositi di legno.

Macchine: Squadratrici singole, doppie e squadrabordatrici.

Caratteristiche: Dente inclinato.

Se usate in condizioni ottimali, garantiscono una durata fino a 80 volte superiore all'articolo corrispondente in HW.

N.B.: Le lame possono essere costruite anche nella versione "Economica" con placchetta di altezza 4 mm. (Nell'ordine sostituire la cifra "6" del codice con il "4")

Es.: DLI24D6LE5 --> Lama Incisore
DLI24D4LE5 --> Lama Incisore "Economica"

Sinistra
Left

Destra
Right

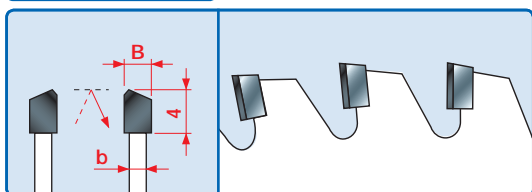

Economica
Throw away

CARATTERISTICHE DEL DENTE - TOOTH'S FEATURES

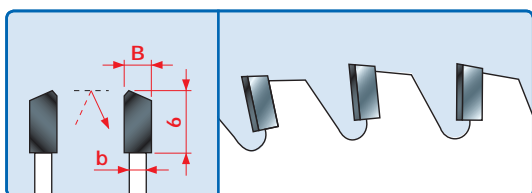

Industriale
Industrial

CARATTERISTICHE DEL DENTE - TOOTH'S FEATURES



> **Application:** PCD scoring sawblade for squaring machines, for cutting with excellent finishes of melamine chipboard, MDF, laminates and gloss lacquered materials.

Machines: Single-side or double-end tenoners and squaring edgbanding machines.

Features: Inclined tooth.

Up to 80 times longer life than the similar HW sawblades.

N.B. The sawblades can also be manufactured in the "Economical" version, with a plate with a height of 4 mm (to order, substitute the number "6" in the code with the number "4").

Es.: DLI24D6LE5 --> Scoring sawblade.
DLI24D4LE5 --> "Economical" scoring sawblade.

