

TR15MD TR15MS

DESTRA
RIGHT
SINISTRA
LEFT

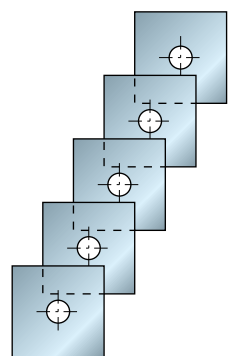
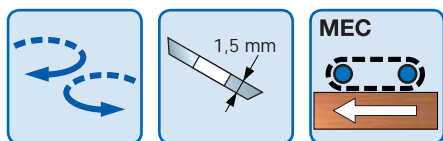

> I coltelli sono disposti seguendo un allineamento elicoidale e si possono utilizzare 8 volte (4 volte a destra + 4 volte a sinistra).

> The knives are set on a spiral providing a shear cutting action. The knives can be used 8 times (4 times for the right hand rotation and 4 times for the left hand rotation).

TRUCIOLATORI CON COLTELLI A GETTARE IN HW T.C.T. HOGGING UNITS WITH TURNOVER KNIVES

D mm	B mm	d mm	Z	R	CODICE/CODE	
					DESTRO/RIGHT	SINISTRO/LEFT
250	30	60	24		TR15MD BA3	TR15MS BA3
250	30	80	24		TR15MD BC3	TR15MS BC3

CODICE CODE	PARTI DI RICAMBIO SPARE PARTS	DIMENSIONI DIMENSIONS
CG01M BA3	COLTELLO / KNIFE	12 x 12 x 1,5
CN09MD AG9	CUNEO DESTRO / RIGHT WEDGE	15 x 11 x 9
CN09MS AG9	CUNEO SINISTRO / LEFT WEDGE	15 x 11 x 9
VT19M AB9	VITE / SCREW	M6 x 22
VT20M AA9	OGIVA / NUT	10 x 11,5 x 6
VT01M AA9	VITE / SCREW	M6 x 10
CB03M AA9	CHIAVE / ALLEN KEY	3 x 110

> **Impiego:** Ideale per la squadratura di pannelli composti, grezzi e rivestiti.

Macchine: Squadratrici singole e doppie.

Caratteristiche:

- Lame applicabili: LT16MD/S - LT18MD/S.
- Dotato di coltelli a gettare in HW, disposti con sviluppo a forma elicoidale.
- Notevole truciolamento.
- Facile avanzamento.

> **Application:** Particularly indicated for squaring wood composites, unprocessed and covered panels.

Machines: Single-side or double-end tenoners.

Features:

- Spare sawblades: LT16MD/S - LT18MD/S.
- Supplied with disposable knives fitted with double spiral disposition.
- Excellent chipping.
- Easy feed rate.



MOZZI PER TRUCIOLATORI MOUNTING SLEEVES FOR HOGGING UNITS

D mm	B mm	d mm	CH - KN	CODICE CODE
		35	10 x 4	MT01M AA9
		40	10 x 4	MT01M BA9

> Il codice MT01M include l'operazione di fissaggio al truciolatore.

N.B.: L'accoppiamento deve essere eseguito in sede e solo con truciolatori Freud.

> Item MT01M includes the fixing operation of the mounting sleeve to the hogging unit.

Note: The fixing must be done in our factory and only on Freud's hoggers. The mounting sleeve must be ordered together with the hogging units item TR15M.

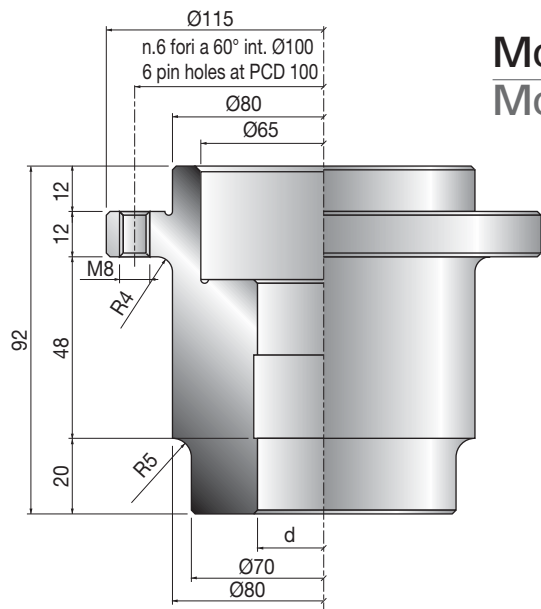

TR16MD TR16MS

DESTRA
RIGHT
SINISTRA
LEFT

TRUCIOLATORI CON INSERTI INTERCAMBIABILI SR06M HOGGING UNITS WITH SR06M INTERCHANGEABLE INSERTS



D(1) mm	B mm	d(2) mm	Z	R	CODICE/CODE	
					DESTRO/RIGHT	SINISTRO/LEFT
200	30	80	16		TR16MD AA3	TR16MS AA3
250	30	60-80	16		TR16MD BA3	TR16MS BA3
300	30	60-80	16		TR16MD CA3	TR16MS CA3

- > **Impiego:** Ideale per la squadratura di pannelli in legno massiccio.
- Macchine:** Squadratrici singole e doppie.
- Caratteristiche:**
- Lame applicabili LT16MD/S - LT18MD/S.
 - Dotato di inserti riaffilabili in HW, disposti con sviluppo a forma elicoidale.
 - Notevole truciolamento.
 - Facile avanzamento.

- > **Application:** Particularly indicated for squaring solid wood panels.

- Machines:** Single-side or double-end tenoners.
- Features:**
- Spare sawblades: LT16MD/S - LT18MDS.
 - Supplied with resharpenable inserts fitted with 2 spiral disposition.
 - Excellent chipping.
 - Easy feed rate.

- (1) Diametro nominale della lama.
Nominal diameter from the sawblade.
- (2) Specificare il foro.
Please specify the bore diameter.

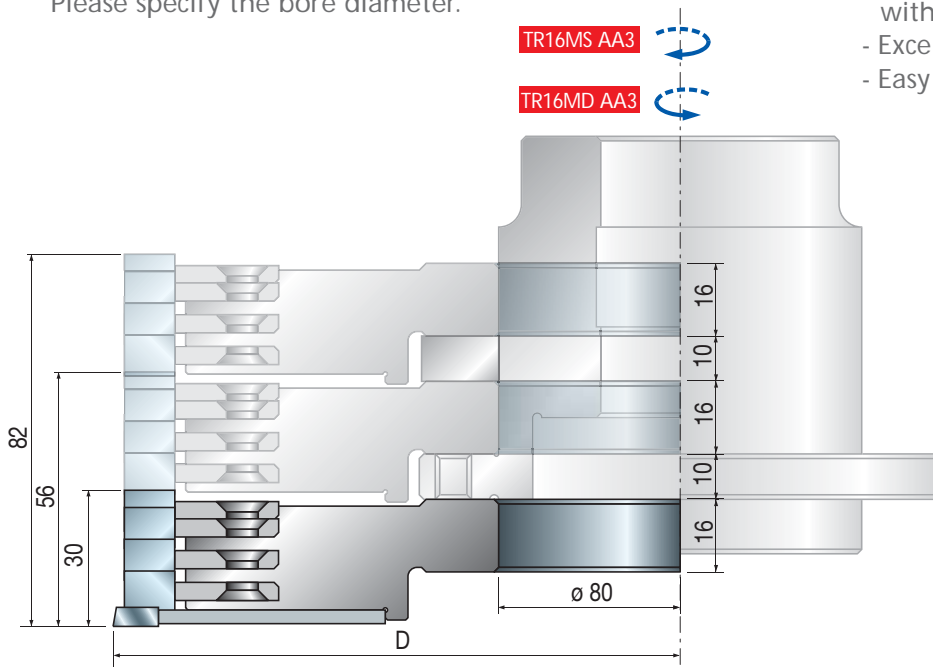

- > Questi utensili possono essere sovrapposti e utilizzati insieme per la lavorazione di una superficie più ampia.
- > These tools can be stacked and used in multiples thus enabling the machining of a wider area.

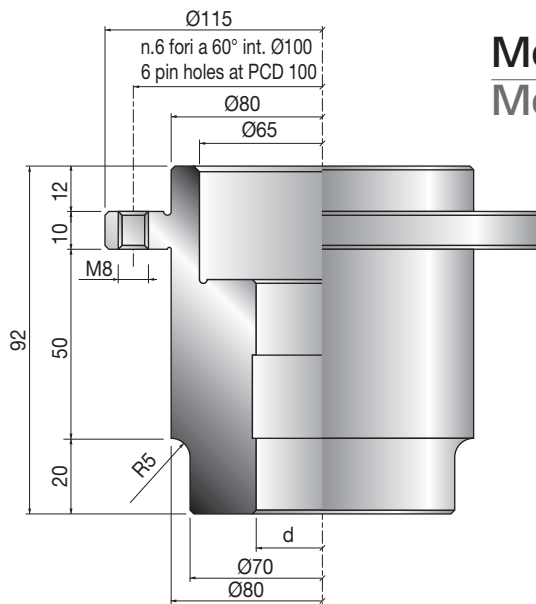

MOZZI PER TRUCIOLATORI MOUNTING SLEEVES FOR HOGGING UNITS

D mm	B mm	d mm	CH - KN	CODICE CODE
		35	10 x 4	MT01M DA9

- > Il codice MT01M include l'operazione di fissaggio al truciolatore.
- N.B.: L'accoppiamento deve essere eseguito in sede e solo con truciolatori Freud.**
- > Item MT01M includes the fixing operation of the mounting sleeve to the hogging unit.
- Note: The fixing must be done in our factory and only on Freud's hoggers. The mounting sleeve must be ordered together with the hogging units item TR16M.**